

**robotron**

**Z 1013**

Mikrorechnerbausatz

Handbuch Teil II B

VEB Robotron-Elektronik Riesa

# ROBOTRON

---

Der Herausgeber ist jederzeit für Korrekturhinweise fachlicher, stilistischer und redaktioneller Art dankbar.

Z 1013

Herausgeber:

VEB Robotron-Elektronik Riesa  
Pausitzer Str. 60  
Riesa  
8400

© VEB Robotron-Elektronik Riesa

III-6-15

digitalisiert: U.Zander, 2011/12 <zander@felix.sax.de>

R O B O T R O N

---

Mikrorechnerbausatz Z 1013

Anlagenteil

VEB Robotron - Elektronik Riesa

# R O B O T R O N

---

Mikrorechnerbausatz Z 1 0 1 3

Anlagen:

-----

	Seite
1 Befehlssatz U 880	3
2 Speicherbereichsaufteilung	11
3 E/A-Adressen	12
4 Arbeitszellen des Monitors	12
5 BASIC-Befehlsliste	13
6 Steckverbinderbelegung	14
7 Zeichensatz/ASCII-Code	16
8 Bildschirmadressen	20
9 Verwendete Schaltkreise	21
10 Zeitverhalten einiger CPU-Funktionen	28
11 Liste des Reassemblers für U 880-Befehle	31
12 Liste des BASIC-Interpreters	37
13 MC-Beispielprogramme	43
14 BASIC-Beispielprogramme	50
15 Belegungsplan	
16 Stromlaufplan	

## Anlage 1: Befehlssatz der CPU 880

### 8-Bit-Ladebefehle

	A	B	C	D	E	H	L	(HL)	(BC)	(DE)	(nn)	n
LD A, .	7F	78	79	7A	7B	7C	7D	7E	0A	1A	3AXXXX	3EXX
LD B, .	47	40	41	42	43	44	45	46				06XX
LD C, .	4F	48	49	4A	4B	4C	4D	4E				0EXX
LD D, .	57	50	51	52	53	54	55	56				16XX
LD E, .	5F	58	59	5A	5B	5C	5D	5E				1EXX
LD H, .	67	60	61	62	63	64	65	66				26XX
LD L, .	6F	68	69	6A	6B	6C	6D	6E				2EXX
LD (HL), .	77	70	71	72	73	74	75					36XX
LD (BC), .	02											
LD (DE), .	12											
LD (nn), .	32XXXX											

	A	B	C	D	E	H	L
LD ., (IX+d)	DD7Exx	DD46XX	DD4EXX	DD56XX	DD5EXX	DD66XX	DD6EXX
LD ., (IY+d)	FD7Exx	FD46XX	FD4EXX	FD56XX	FD5EXX	FD66XX	FD6EXX
LD (IX+d), .	DD77XX	DD70XX	DD71XX	DD72XX	DD73XX	DD74XX	DD75XX
LD (IY+d), .	FD77XX	FD70XX	FD71XX	FD72XX	FD73XX	FD74XX	FD75XX

LD (IX+d),n DD36ddnn  
 LD (IY+d),n FD36ddnn

		S	Z	H	P/V	N	C
LD A,I	ED57	*	*	0	*	0	-
LD A,R	ED5F	*	*	0	*	0	-
LD I,A	ED47	-	-	-	-	-	-
LD A,A	ED4F	-	-	-	-	-	-

### 16-Bit-Ladebefehle

	BC	DE	HL	SP	IX	IY
LD .., nn	01XXXX	11XXXX	21XXXX	31XXXX	DD21XXXX	FD21XXXX
LD .., (nn)	ED4BXXXX	ED5BXXXX	2AXXXX	ED7BXXXX	DD2AXXXX	FD2AXXXX
LD (nn), ..	ED43XXXX	ED53XXXX	22XXXX	ED73XXXX	DD22XXXX	FD22XXXX
LD SP, ..			F9		DDF9	FDF)

	BC	DE	HL	AF	IX	IY
PUSH ..	C5	D5	E5	F5	DDE5	FDE5
POP ..	C1	D1	E1	F1	DDE1	FDE1

EX (SP), HL	B3		EX DE, HL	EB
EX (SP), IX	DDE3		EXAF	08
EX (SP), IY	FDE3		EXX	D9 (BC-BC' DE-DE' HL-HL')

### Blocktransfer- und Suchbefehle

		S	Z	H	P/V	N	C	
LDI	EDA0	-	-	0	*	0	-	LD (DE), (HL); INC HL; INC DE; DEC BC
LDIR	EDB0	-	-	0	0	0	-	wie LDI, wiederholen bis BC=0
LDD	EDA8	-	-	0	*	0	-	LD (DE), (HL); DEC HL; DEC DE; DEC BC
LDDR	EDB8	-	-	0	0	0	-	wie LDD, wiederholen bis BC=0
CPI	EDA1	*	*	*	*	1	-	LD A, (HL); INC HL; DEC BC
CPIR	EDB1	*	*	*	*	1	-	wie CPI, wiederholen bis BC=0 oder Zeichen gefunden
CPD		*	*	*	*	1	-	LD A, (HL); DEC HL; DEC BC
CPDR		*	*	*	*	1	-	wie CPD, wiederholen bis BC=0 oder Zeichen gefunden

## Sprungbefehle

	Z	NZ	C	NC	PE	PC	M	P
JP..	CAXXXX	C2XXXX	DAXXXX	D2XXXX	EAXXXX	E2XXXX	FAXXXX	F2XXXX
CA..	CCXXXX	C4XXXX	DCXXXX	D4XXXX	ECXXXX	E4XXXX	FCXXXX	F4XXXX
RE..	C8	C0	D8	D0	E8	E0	F8	F0
JR..	28XX	20XX	38XX	30XX				

	unbedingt	(HL	(IX)	(IY)				
JMP	C3XXXX	E9	DDE9	FDE9				
CALL	CDXXXX							
RET	C9							
JR	18XX							
RST	00 08 10 18 20 28 30 38							
	C7 CF D7 DF E7 EF F7 FF							
DJNZ	10XX	DEC B;	JRNZ e					
RETI	ED4D	zurück vom Interrupt						
RETN	ED45	zurück vom nicht maskierbaren Interrupt						

## CPU-Steuerbefehle

		S	Z	H	P/V	N	C	
NOP	00	-	-	-	-	-	-	Leerbefehl
HALT	76	-	-	-	-	-	-	
CCF	3F	-	-	*	-	0	*	Komplementiere Carry-Flag
SCF	37	-	-	0	-	0	1	Setze Carry Flag
EI	FB	-	-	-	-	-	-	Interrupts freigeben
DI	F3	-	-	-	-	-	-	Interrupts sperren
IM 0	ED46	-	-	-	-	-	-	Interrupt-Modus 0
IM 1	ED56	-	-	-	-	-	-	Interrupt-Modus 1
IM 2	ED5E	-	-	-	-	-	-	Interrupt-Modus 2

## Ein-/Ausgabebefehle

	A	B	C	D	E	H	L	S	/	H	P/V	N	C	
IN	ED78	ED40	ED48	ED50	ED58	ED60	ED68	*	*	0	*	0	-	
OUT	ED79	ED41	ED49	ED51	ED59	ED61	ED69	-	-	-	-	-	-	
	(Kanaladresse in C)													
INF	ED70	Setzen des Flag-Registers							*	*	?	*	0	-
	(Kanaladresse in C)													

		S	Z	H	P/V	N	C	
IN n	DBXX	-	-	-	-	-	-	Kanaladresse 'n'
OUT n	D3XX	-	-	-	-	-	-	Kanaladresse 'n'
INI	EDA2	?	*	?	?	1	-	IN (HL),(C); INC HL; DEC B
INIR	EDB2	?	1	?	?	1	-	wie INI, wiederholen solange B<>0
IND	EDAA	?	*	?	?	1	-	IN (HL),(C); DEC HL; DEC B
INDR	EDBA	?	1	?	?	1	-	wie IND, wiederholen solange B<>0
OUTI	EDA3	?	*	?	?	1	-	(C),(HL); INC HL; DEC B
OTIR	EDB3	?	1	?	?	1	-	OUTI, wiederholen solange B<>0
OUTD	EDAB	?	*	?	?	1	-	(C),(HL); DEC HL; DEC B
OTDR	EDBB	?	1	?	?	1	-	OUTD, wiederholen solange B<>0



### 8-Bit Arithmetische und Logische Befehle

	B	C	D	E	H	L	(HL)	A	n	(IX+d)	(IY+d)	S	Z	H	P/V	N	C
ADD	80	81	82	83	84	85	86	87	C6XX	DD87XX	FD86XX	*	*	*	*	0	*
ADC	88	89	8A	8B	8C	8D	8E	8F	CEXX	DD8EXX	FD8EXX	*	*	*	*	0	*
SUB	90	91	92	93	94	95	96	97	D6XX	D97XX	FD96XX	*	*	*	*	1	*
SBC	98	99	9A	9B	9C	9D	9E	9F	DEXX	DD9EXX	FD9EXX	*	*	*	*	1	*
AND	A0	A1	A2	A3	A4	A5	A6	A7	E6XX	DDA6XX	FDA6XX	*	*	1	*	0	0
XOR	A8	A9	AA	AB	AC	AD	AE	AF	EEXX	DDAEXX	FDAEXX	*	*	1	*	0	0
OR	B0	B1	B2	B3	B4	B5	B6	B7	F6XX	DDB6XX	FDB6XX	*	*	1	*	0	0
CMP	B8	B9	BA	BB	BC	BD	BE	BF	FEXX	DDBEXX	FDBEXX	*	*	*	*	1	*
INC	04	0C	14	1C	24	2C	34	3C		DD34XX	FD34XX	*	*	*	*	0	-
DEC	05	0D	15	1D	25	2D	35	3D		DD35XX	FD35XX	*	*	*	*	1	-

	S	/	H	P/V	N	C		
DAA	27	*	*	*	*	-	*	BCD-Korrektur im A-Register
CPL	2F	-	-	1	-	1	-	Komplementiere A-Register (1er Komplement)
NEG	ED44	*	*	*	*	1	*	Komplementiere A-Register (2er Komplement)

### 16-Bit Arithmetische und Logische Befehle

	BC	DE	HL	SP	IX	IY	S	Z	H	P/V	N	C
INC .	03	13	23	33	DD23	FD23	-	-	-	-	-	-
DEC .	0B	1B	2B	3b	DD2B	FD2B	-	-	-	-	-	-
ADD HL, .	09	19	29	39			-	-	*	-	0	*
ADC HL, .	ED4A	ED5A	ED6A	ED7A			*	*	*	*	0	*
SBC HL, .	ED42	ED52	ED62	ED72			*	*	*	*	1	*
ADD IX, .	DD09	DD19		DD39	DD29		-	-	*	-	0	*
ADD IY, .	FD09	FD19		FD39		FD29	-	-	*	-	0	*

## Rotations- und Schiebepfehle

	B	C	D	E	H	L	(HL)	A	(IX+d)	(IY+d)
RR	CB18	CB19	CB1A	CB1B	CB1C	CB1D	CB1E	CB1F	DDCBXX1E	FDCBXX1E
RL	CB10	CB11	CB12	CB13	CB14	CB15	CB16	CB17	DDCBXX16	FDCBXX16
RRC	CB08	CB09	CB0A	CB0B	CB0C	CB0D	CB0E	CB0F	DDCBXX0E	FDCBXX0E
RLC	CB00	CB01	CB02	CB03	CB04	CB05	CB06	CB07	DDCBXX06	FDCBXX06
SRA	CB28	CB29	CB2A	CB2B	CB2C	CB2D	CB2E	CB2F	DDCBXX2E	FDCBXX2E
SLA	CB20	CB21	CB22	CB23	CB24	CB25	CB26	CB27	DDCBXX26	FDCBXX26
SRL	CB38	CB39	CB3A	CB3B	CB3C	CB3D	CB3E	CB3F	DDCBXX3E	FDCBXX3E

	S	/	H	P/V	N	C	
RR/RL	*	*	0	*	0	*	Rotiere Register rechts/links durch Carry
RRC/RLC	*	*	0	*	0	*	Rotiere Register rechts/links
SRA/SLA	*	*	0	*	0	*	Schiebe Register rechts/links arithmetisch
SRL	*	*	0	*	0	*	Schiebe Register rechts/links logisch

		S	/	H	P/V	N	C	
RRCA	0F	-	-	0	-	0	*	Rotiere Register A rechts
RLCA	07	-	-	0	-	0	*	Rotiere Register A links
RRA	1F	-	-	0	-	0	*	Rotiere Register A rechts durch Carry
RLA	17	-	-	0	-	0	*	Rotiere Register A links durch Carry
RLD (HL)	ED6F	*	*	0	*	0	-	Rotiere Ziffer links zwischen A-Register und (HL)
RRD (HL)	ED67	*	*	0	*	0	-	Rotiere Ziffer rechts zwischen A-Register und (HL)

## Einzelbitbefehle

	B	C	D	E	H	L	(HL)	A	(IX+d)	(IY+d)
BIT 0,,	CB40	CB41	CB42	CB43	CB44	CB45	CB46	CB47	DDCBXX46	FDCBXX46
BIT 1,,	CB48	CB49	CB4A	CB4B	CB4C	CB4D	CB4E	CB4F	DDCBXX46	FDCBXX46
BIT 2,,	CB50	CB51	CB52	CB53	CB54	CB55	CB56	CB57	DDCBXX46	FDCBXX46
BIT 3,,	CB58	CB59	CB5A	CB5B	CB5C	CB5D	CB5E	CB5F	DDCBXX46	FDCBXX46
BIT 4,,	CB60	CB61	CB62	CB63	CB64	CB65	CB66	CB67	DDCBXX46	FDCBXX46
BIT 5,,	CB68	CB69	CB6A	CB6B	CB6C	CB6D	CB6E	CB6F	DDCBXX46	FDCBXX46
BIT 6,,	CB70	CB71	CB72	CB	CB	CB	CB	CB	DDCBXX46	FDCBXX46
BIT 7,,	CB78	CB79	CB7A	CB	CB	CB	CB	CB	DDCBXX46	FDCBXX46
RES 0,,	CB80	CB81	CB82	CB	CB	CB	CB	CB	DDCBXX46	FDCBXX46
RES 1,,	CB88	CB89	CB8A	CB	CB	CB	CB	CB	DDCBXX46	FDCBXX46
RES 2,,	CB90	CB91	CB92	CB	CB	CB	CB	CB	DDCBXX46	FDCBXX46
RES 3,,	CB98	CB99	CB9A	CB	CB	CB	CB	CB	DDCBXX46	FDCBXX46
RES 4,,	CBA0	CBA1	CBA2	CB	CB	CB	CB	CB	DDCBXX46	FDCBXX46
RES 5,,	CBA8	CBA9	CBAA	CB	CB	CB	CB	CB	DDCBXX46	FDCBXX46
RES 6,,	CBB0	CBB1	CBB2	CB	CB	CB	CB	CB	DDCBXX46	FDCBXX46
RES 7,,	CBB8	CBB9	CBBA	CB	CB	CB	CB	CB	DDCBXX46	FDCBXX46
SET 0,,	CBC0	CBC1	CBC2	CB	CB	CB	CB	CB	DDCBXX46	FDCBXX46
SET 1,,	CBC8	CBC9	CBCA	CB	CB	CB	CB	CB	DDCBXX46	FDCBXX46
SET 2,,	CBD0	CBD1	CBD2	CB	CB	CB	CB	CB	DDCBXX46	FDCBXX46
SET 3,,	CBD8	CBD9	CBDA	CB	CB	CB	CB	CB	DDCBXX46	FDCBXX46
SET 4,,	CBE0	CBE1	CBE2	CB	CB	CB	CB	CB	DDCBXX46	FDCBXX46
SET 5,,	CBE8	CBE9	CBEA	CB	CB	CB	CB	CB	DDCBXX46	FDCBXX46
SET 6,,	CBF0	CBF1	CBF2	CB	CB	CB	CB	CB	DDCBXX46	FDCBXX46
SET 7,,	CBF8	CBF9	CBFA	CB	CB	CB	CB	CB	DDCBXX46	FDCBXX46

**Flagbeeinflussung der Einzelbitbefehle:**

	S	/	H	P/V	N	C
BIT	?	*	1	?	0	-
SET	-	-	-	-	-	-
RES	-	-	-	-	-	-

**Flag-Register**

BIT	7	6	5	4	3	2	1	0
	S	Z	X	H	X	P/V	N	C

		Frage, ob		
		gesetzt	nicht gesetzt	wird gesetzt bei
C	Carry-Flag	C	NC	Übertrag von Bit 7
N	Add-/Subtract-Flag			Subtraktionen
P/V	Parity-/Overflow-Flag	FE	PC	gerader Parität
H	Half-Carry-Flag			Übertrag von Bit 3
Z	Zero-Flag	Z	NZ	Ergebnis 0
S	Sign-Flag	M	P	neg. Ergebnis
X	nicht verwendet			

Beeinflussung  
der Flags:

- 1 gesetzt
- 0 zurückgesetzt
- \* abhängig vom Ergebnis einer Operation
- nicht beeinflusst
- ? unbestimmt

## Anlage 2: Speicherbereichsaufteilung

Speicher:

FFFF	frei	
FC00	frei	
F800	frei	
F000	Monitor	2 KByte ROM/EEPROM /DK14 + 15
EC00	Bildwiederholungspeicher	1 KByte SRAM /DK13
E800	frei	
E400	frei	
E000		/DK10
	nicht belegt	
4000 3FFF (Z1013.01) bzw. 0400 03FF (Z1013.12)	Nutzerspeicher	
00B0	Stack	
0000	Arbeitspeicher	

### Anlage 3: E/A Adressen

#### **E/A-Adressen:**

0000	/IOSEL0	PIO	PORT A	Daten
01				Steuerwort
02			PORT B	Daten
03				Steuerwort
0004	/IOSEL1			
05				
06				
07				
0008	/IOSEL2	Tastaturspalten-Treiber		
09				

### Anlage 4: Arbeitszellen des Monitors

Adresse	Länge	Bedeutung
0000	3	RST 0H, frei für den Anwender
0003	1	Zwischenspeicher f. Spezifikationsbyte RST 20H
0004	1	Merkzelle für letztes Zeichen von Tastatur
0005	3	frei für Anwendung eines zentralen CALL 5
0008	3	RST 8H, frei für den Anwender
000B	2	Zwischenspeicher für BREAK-Adresse
000D	3	Zwischenspeicher für Operandenfolge bei BREAK
0010	3	RST 10H, frei für den Anwender
0013	3	Arbeitszellen für INHEX-Routine
0016	2	(SOIL) Anfangsadresse der Eingabezeile
0018	3	RST 18H, frei fuer den Anwender
001B	2	(ARG1) Parameter 1
001D	2	(ARG2) Parameter 2
001F	1	Code-Zwischenspeicher fuer OUTCH
0020	3	RST 20H, zentr. Anspruch f. Monitorroutinen
0023	2	(ARG3) Parameter 3
0025	2	2. Adresse der Eingabezeile
0027	1	Merkzelle ASCII(=0)/Grafik(=80H)
0028	3	RST 28H, frei für den Anwender
002B	2	(CURSR) aktuelle Cursorposition
002D	1	Cursor-Zwischenspeicher
002F	1	Merkzelle für Phasenlage bei CLOAD
0030	3	RST 30H, frei für den Anwender
0033	2	Laenge der Synchronisationslücke bei CSAVE
0035	2	Beginn Tastencodetabelle
0038	3	RST 38H, wird als zentraler Fehleranspruch verwendet, bei Eintritt in den Monitor erscheint ?#
003B	12	Fortsetzung Tastencodetabelle
0047	2	Rolldistanz bei OUTCH
0049	2	Anfangsadresse des BS Rollbereiches
004B	2	Endadresse+1 des Rollbereiches
004D	24	Registerrettebereich
0066	3	NMI, frei für den Anwender
0090	>32	Anwender-Stackbereich (Stack läuft nach unten!)
00B0	≥32	System-Stackbereich (Stack läuft nach unten!)
00B0	≤32	frei für Kommandoerweiterungstabelle des Monitors, welche über @... erreichbar ist
00E0	32	Kassetten-Überspielbereich (Kopfdaten)

## Anlage 5: BASIC-Befehlsliste

### **Kommandos:**

BYE	B.	Verlassen BASIC
CLOAD	CL.	Laden von Kassette
CSAVE	CS.	Laden auf Kassette
LIST	L.	Auflisten BASIC-Programm
NEW	N.	Löschen BASIC-Programm
RUN	R.	Start

### **Befehle:**

ABS	A.	absoluter Betrag
BYTE	BYT.	Ausgabe hexadezimal 8-Bit-Wert
CALL	C.	Aufruf Maschinenunterprogramm
FOR	F.	Schleifenbeginn
GOSUB	GOS	Aufruf BASIC-Unterprogramm
GOTO	G.	Sprungbefehl
HEX	H.	Umwandlung hexadezimal
I\$		Eingabe Zeichenkette
IF		Bedingungsabfrage
IN		Eingabe von Maschinenport
INCHAR	INC.	Eingabe Zeichen von Tastatur
INPUT	INP.	Eingabe Zahl
LEN	LE.	Pseudovariablen, enthält Länge der zuletzt eingegebenen Zeichenkette
NEXT	N.	Schleifenende
O\$		Ausgabe Zeichenkette
OUT		Ausgabe auf Maschinenport
OUTCHAR	OUTC.	Ausgabe Zeichen
PEEK	PE.	direkter Speicherzugriff
POKE	PO.	direkter Speicherzugriff
PRINT	PR.	Ausgabe
REM		Kommentarkennzeichen
RETURN	RE.	Rückkehr vom BASIC-Unterprogramm
RND	RN.	Zufallsgenerator
SIZE	S.	Pseudovariablen, enthält Ausgabe über verfügbaren Speicher
STEP	STE.	Schrittweite
STOP	STO.	Programmende
TAB	T.	Ausgabe Zwischenraum
TO		Festlegung Schleifenendwert
TOP		Pseudovariablen, erster freier Speicherplatz
WORD	W.	Ausgabe hexadezimal 16-Bit-Wert

### **Arithmetische Operationen:**

+	Addition
-	Subtraktion
/	Division (ganzzahlig)
*	Multiplikation

### Vergleichsparameter:

>=	größer gleich
#	ungleich
>	größer
=	gleich
<=	kleiner gleich
<	kleiner

### Anlage 6: Steckverbinderbelegung

X1 Systemsteckverbinder

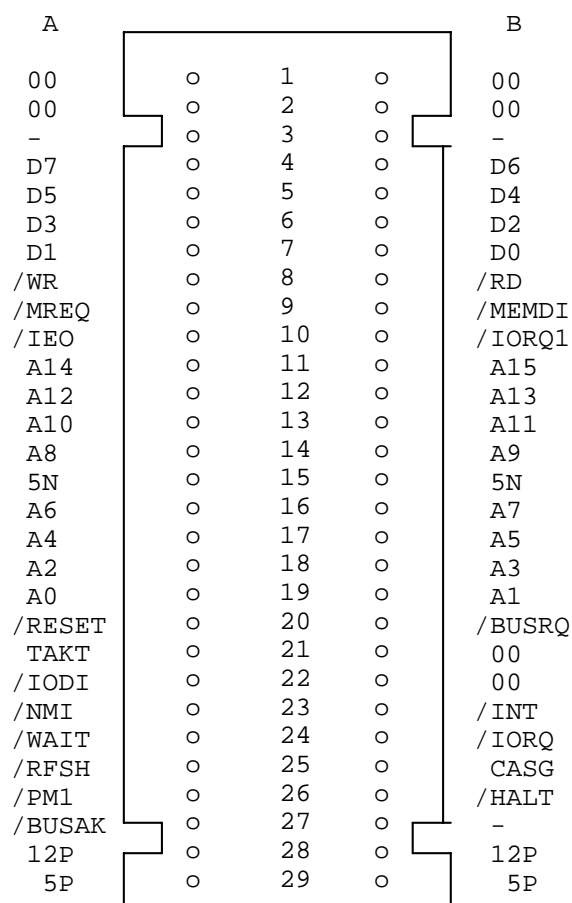



X2 Lötkeim für Folienflachtastatur

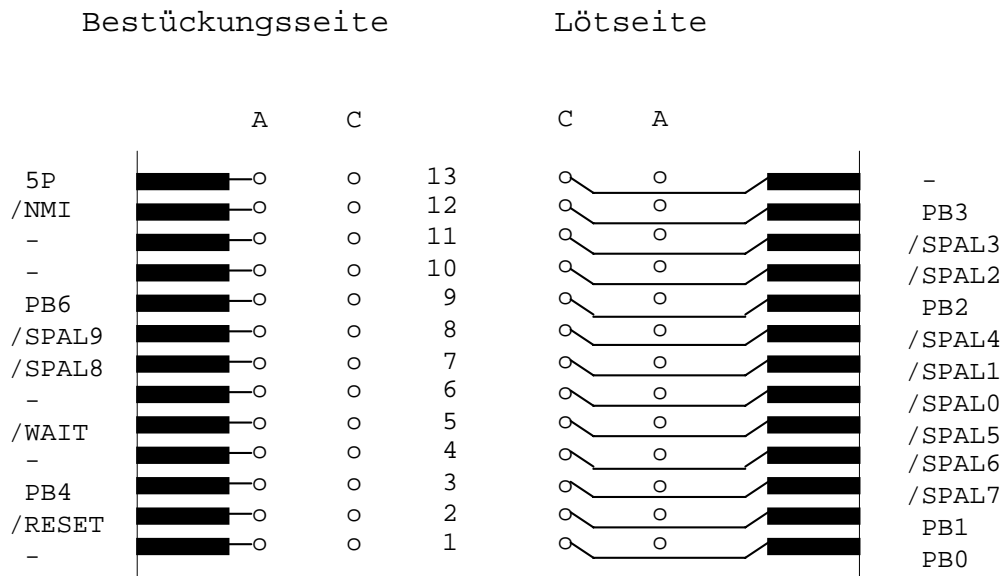

X4 Anwendertor

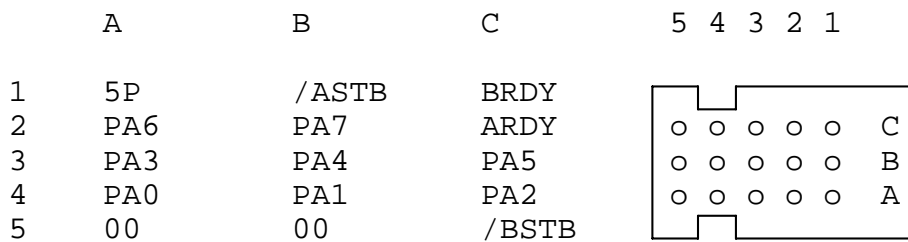

X5 Magnetbandanschluß

- 1 Ausgabe
- 2 Masse
- 3 Eingabe
- 4 Ausgabe
- 5 Eingabe

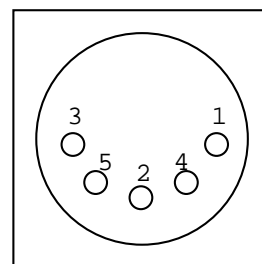

## Anlage 7: Zeichensatz/ASCII-Code

Dez.	Hex.	Zeichen	Dez.	Hex.	Zeichen
32	20	Space	80	50	P
33	21	!	81	51	Q
34	22	"	82	52	R
35	23	#	83	53	S
36	24	\$	84	54	T
37	25	%	85	55	U
38	26	&	86	56	V
39	27	'	87	57	W
40	28	(	88	58	X
41	29	)	89	59	Y
42	2A	*	90	5A	Z
43	2B	+	91	5B	[
44	2C	, (comma)	92	5C	\
45	2D	- (minus)	93	5D	]
46	2E	. (period)	94	5E	^
47	2F	/	95	5F	_ (underline)
48	30	0	96	60	`
49	31	1	97	61	a
50	32	2	98	62	b
51	33	3	99	63	c
52	34	4	100	64	d
53	35	5	101	65	e
54	36	6	102	66	f
55	37	7	103	67	g
56	38	8	104	68	h
57	39	9	105	69	i
58	3A	:	106	6A	j
59	3B	;	107	6B	k
60	3C	<	108	6C	l
61	3D	=	109	6D	m
62	3E	>	110	6E	n
63	3F	?	111	6F	o
64	40	@	112	70	p
65	41	A	113	71	q
66	42	B	114	72	r
67	43	C	115	73	s
68	44	D	116	74	t
69	45	E	117	75	u
70	46	F	118	76	v
71	47	G	119	77	w
72	48	H	120	78	x
73	49	I	121	79	y
74	4A	J	122	7A	z
75	4B	K	123	7B	{
76	4C	L	124	7C	
77	4D	M	125	7D	}
78	4E	N	126	7E	~
79	4F	O	127	7F	

ASCII-Code = **A**merican **S**tandard **C**ode of **I**nformation **I**nterchange

### Codierung der Grafiksymbole













D = Dezimal, H = Hexadezimal, G = Grafikzeichen

D	H	G	D	H	G	D	H	G	D	H	G
128	80		160	A0		192	C0		224	E0	
129	81		161	A1		193	C1		225	E1	
130	82		162	A2		194	C2		226	E2	
131	83		163	A3		195	C3		227	E3	
132	84		164	A4		196	C4		228	E4	
133	85		165	A5		197	C5		229	E5	
134	86		166	A6		198	C6		230	E6	
135	87		167	A7		199	C7		231	E7	
136	88		168	A8		200	C8		232	E8	
137	89		169	A9		201	C9		233	E9	
138	8A		170	AA		202	CA		234	EA	
139	8B		171	AB		203	CB		235	EB	
140	8C		172	AC		204	CC		236	EC	
141	8D		173	AD		205	CD		237	ED	
142	8E		174	AE		206	CE		238	EE	
143	8F		175	AF		207	CF		239	EF	

D = Dezimal, H = Hexadezimal, G = Grafikzeichen

D	H	G	D	H	G	D	H	G	D	H	G
144	90		176	B0		208	D0		240	F0	
145	91		177	B1		209	D1		241	F1	
146	92		178	B2		210	D2		242	F2	
147	93		179	B3		211	D3		243	F3	
148	94		180	B4		212	D4		244	F4	
149	95		181	B5		213	D5		245	F5	
150	96		182	B6		214	D6		246	F6	
151	97		183	B7		215	D7		247	F7	
152	98		184	B8		216	D8		248	F8	
153	99		185	B9		217	D9		249	F9	
154	9A		186	BA		218	DA		250	FA	
155	9B		187	BB		219	DB		251	FB	
156	9C		188	BC		220	DC		252	FC	
157	9D		189	BD		221	DD		253	FD	
158	9E		190	BE		222	DE		254	FE	
159	9F		191	BF		223	DF		255	FF	

## Schachfiguren

	weiß	D	H		schwarz	D	H
Bauer		23	17		14	0E	
		26	1A		17	11	
Turm		24	18		15	0F	
		26	1A		17	11	
Springer		25	19		16	10	
		26	1A		17	11	
Läufer		27	1B		18	12	
		28	1C		19	13	
Dame		29	1D		20	14	
		31	1F		22	16	
König		30	1E		21	15	
		31	1F		22	16	

# Anlage 8

# Bildschirmadressen

	Spalte	0	1	2	3	4	5	6	7	8	9	A	B	C	D	E	F	10	11	12	13	14	15	16	17	18	19	1A	1B	1C	1D	1E	1F		
Hex	Zeile	0	1	2	3	4	5	6	7	8	9	10	11	12	13	14	15	16	17	18	19	20	21	22	23	24	25	26	27	28	29	30	31		
EC00	0																																		
EC20	1																																		
EC40	2																																		
EC60	3																																		
EC80	4																																		
ECA0	5																																		
ECC0	6																																		
ECE0	7																																		
ED00	8																																		
ED20	9																																		
ED40	10																																		
ED60	11																																		
ED80	12																																		
EDA0	13																																		
EDC0	14																																		
EDE0	15																																		
EE00	16																																		
EE20	17																																		
EE40	18																																		
EE60	19																																		
EE80	20																																		
EEA0	21																																		
EEC0	22																																		
EEE0	23																																		
EF00	24																																		
EF20	25																																		
EF40	26																																		
EF60	27																																		
EF80	28																																		
EFA0	29																																		
EFC0	30																																		
EFE0	31																																		

Bildschirmbelegung: EC00 . . . . EFFF

Beispiel: Zeile 15, Spalte 28

Adresse:        EDE0  
                   + 1C  
                   -----  
                   EDEF

## Anlage 9: Verwendete Schaltkreise

### Grundgatter Gehäuse

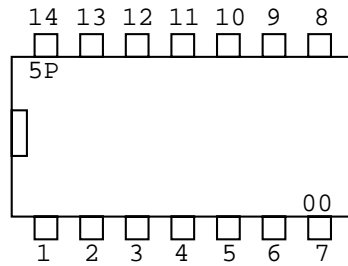

### Schaltzeichen

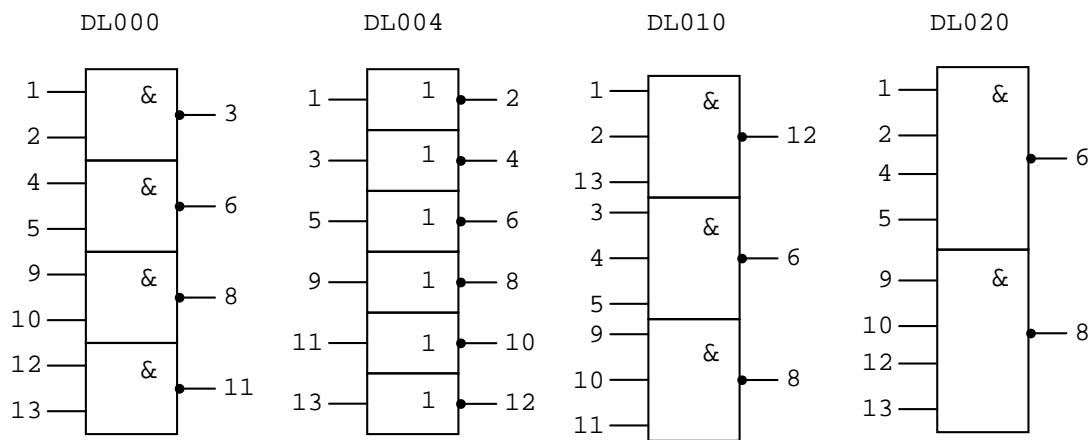

### D-Flip-Flop

Statisch gesteuertes D-FF D175

### Gehäuse

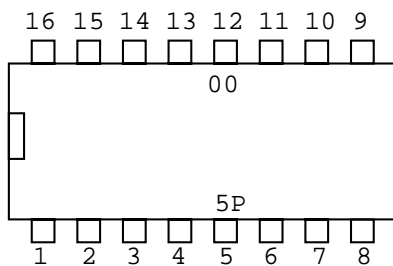

### Schaltzeichen

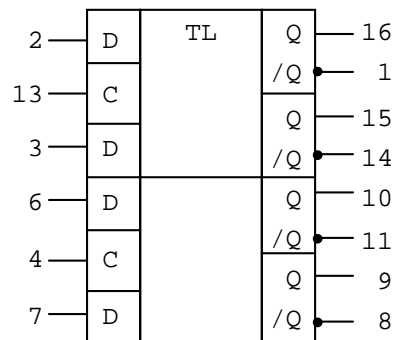

Erläuterung: C - Takteingang  
D - Dateneingang  
Q - Datenausgang  
/Q - negierter Datenausgang

H-Pegel an C bewirkt Übernahme von D an Q.  
Führt C L-Pegel, dann führen Änderungen an D zu keinen Änderungen an Q.

## Flankengesteuertes D-FF DL074

Gehäuse wie Grundgatter

Schaltzeichen:

Erläuterung:

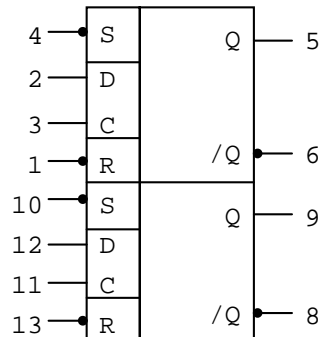

S - Eingang Setzen:  $S=0 \Rightarrow Q=1$   
 R - Eingang Rücksetzen:  $R=0 \Rightarrow Q=0$   
 C - Takt: - Flanke führt zur Übernahme der Information von D an Q ( $S=R=1$ )  
 D - Dateneingang

## Zähler

Asynchroner 4-Bit-Binärzähler DL093

Gehäuse:

Schaltzeichen:

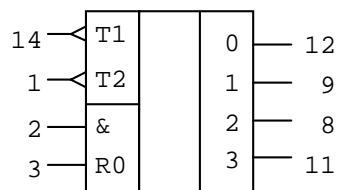
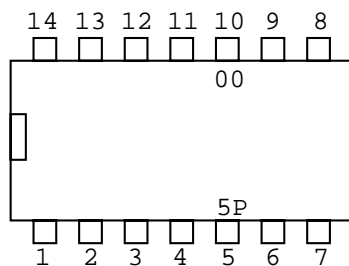

Erläuterung:

T1 - H-L-Flanke schaltet Ausgang 0

T2 - Zähl Eingang für Ausgänge 1,2,3 schaltet mit H-L-Flanke

H-Pegel an den Rückstelleingängen R0 setzt Ausgänge auf L



Schieberegister

4-Bit-Rechts/Links-Schieberegister D195

Gehäuse: wie Grundgatter

Schaltzeichen:

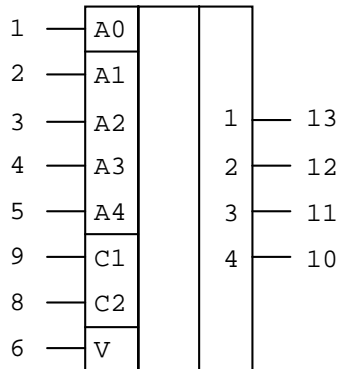

Erläuterung:

- A0 - serieller Dateneingang
- A1...A4 - parallele Dateneingänge (A4 - niederwertigstes Bit)
- 1...4 - parallele Datenausgänge (analog A1...A4)
- C1, C2 - Schiebeteingänge
- V - Steuereingang

C1	C2	V	A0	A1...A4	
x		1	x	Daten	Parallel Laden und Schieben
	x	0	Daten x		Seriell Schieben

Multiplexer

4facher 2-zu-1-Multiplexer DL257 (3!!!38tt)

Gehäuse:

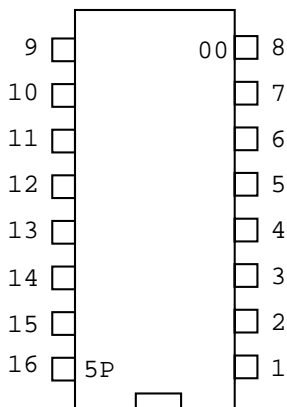

Schaltzeichen:

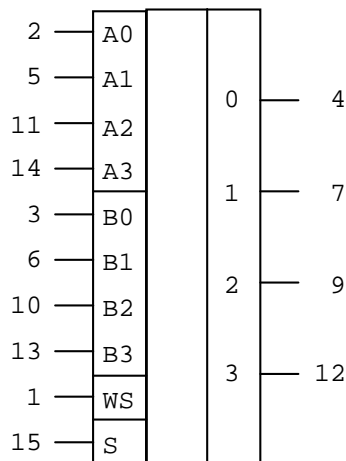



## Bustreiber

### 8-Bit bidirektionaler Bustreiber DS8286

Gehäuse:

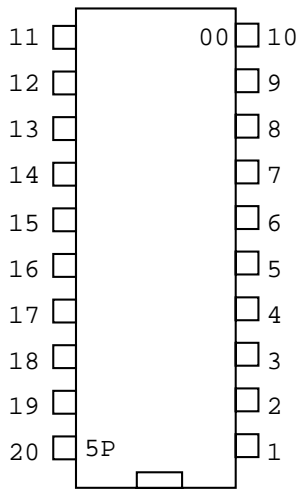

Schaltzeichen:

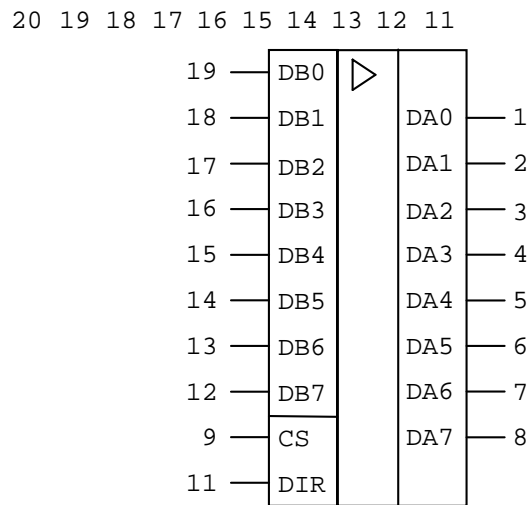

Erläuterung:	/CS	DIR
	0	0
	0	1
	1	x

Daten von DB nach DA  
 Daten von DA nach DB  
 DA und DB hochohmig

## Speicherschaltkreise

### PROM U2616

Gehäuse:

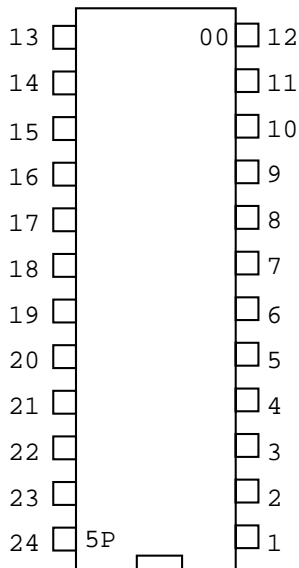

Schaltzeichen:

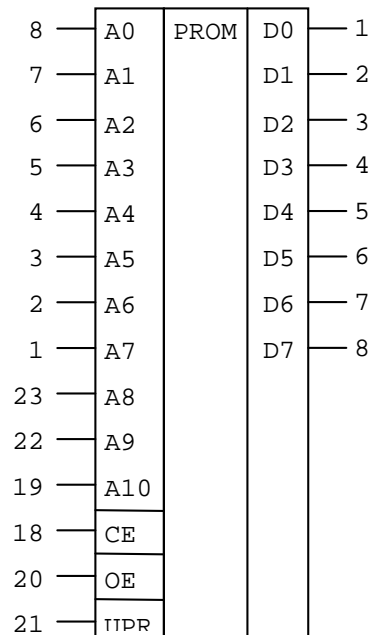

Erläuterung:	A0...A10	D0...D7	/CE	/OE	U <sub>PR</sub>
	: Adreßeingänge	: Datenausgänge	: L-Pegel aktiviert PROM	: L-Pegel gibt Ausgänge frei	: Programmieringang

Statischer RAM U2114

Gehäuse:

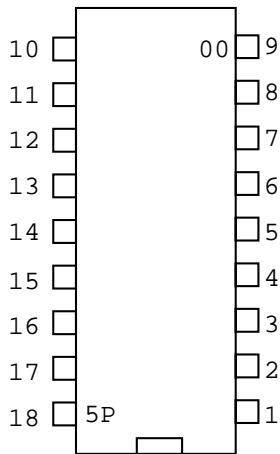

Schaltzeichen:

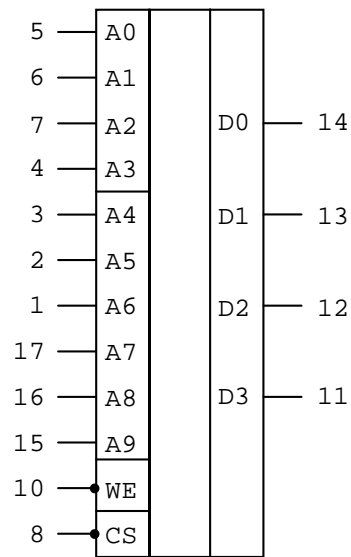

Erläuterung: A0...A9 : Adreßeingänge  
 D0...D3 : Datenein- und -ausgänge  
 /WE : 0 - Daten schreiben  
 : 1 - Daten lesen  
 /CS : Bausteinfreigabe

Dynamischer RAM U256 (K565RU3=3!"!9<Z) und K565RU6=3!"!9<"

Gehäuse:

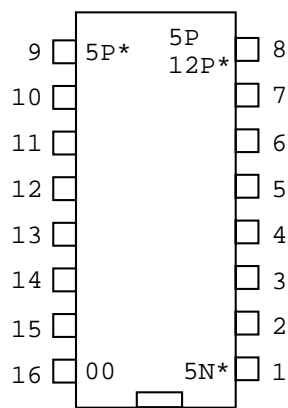

\* für U256

Schaltzeichen:

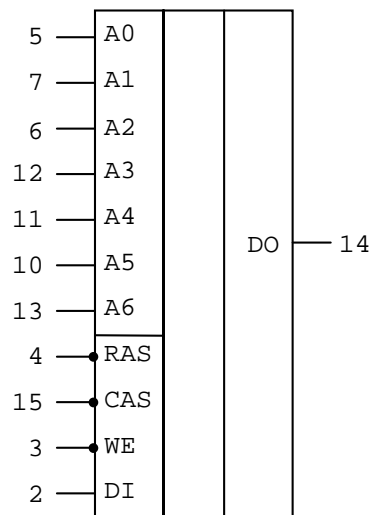

Erläuterung: A0...A6 : Adreßeingänge  
 DI : Datenausgang  
 DO : Datenausgang  
 RAS, CAS : s. Abschnitt 3.3  
 WE : s. U2114

Mikroprozessor

U880

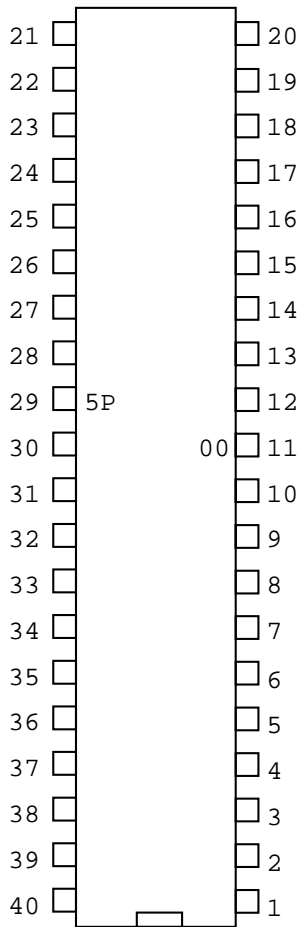

Parallel E/A

U855

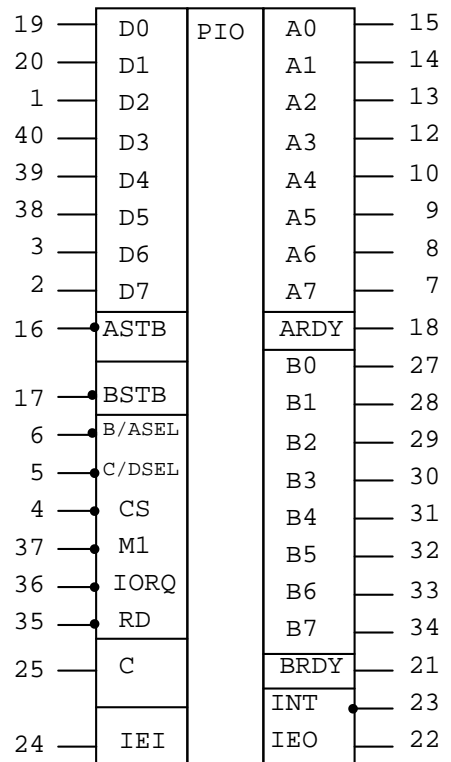
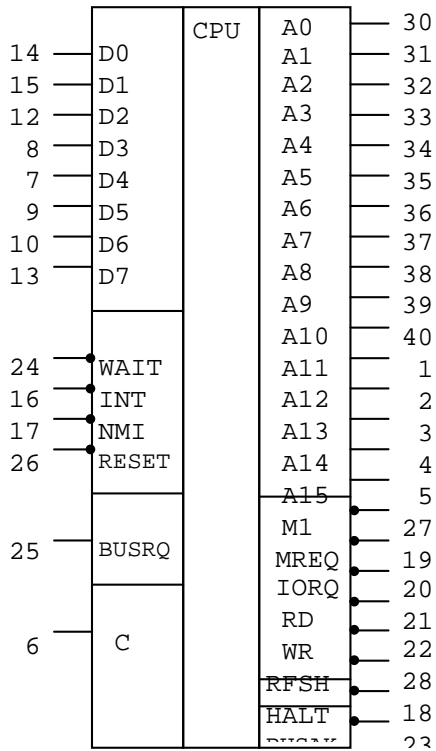
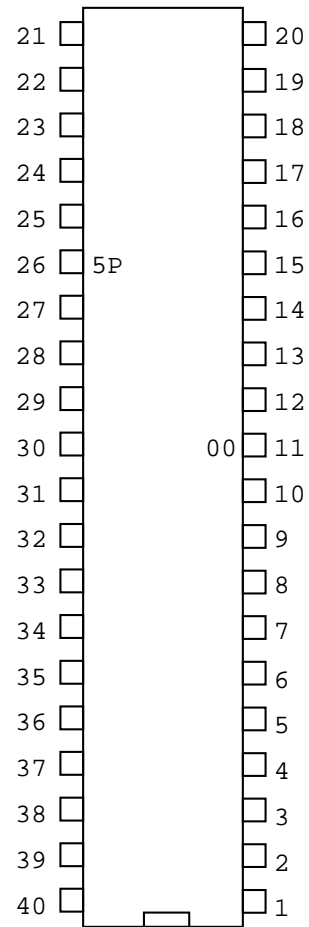

Erläuterungen s. Handbuch

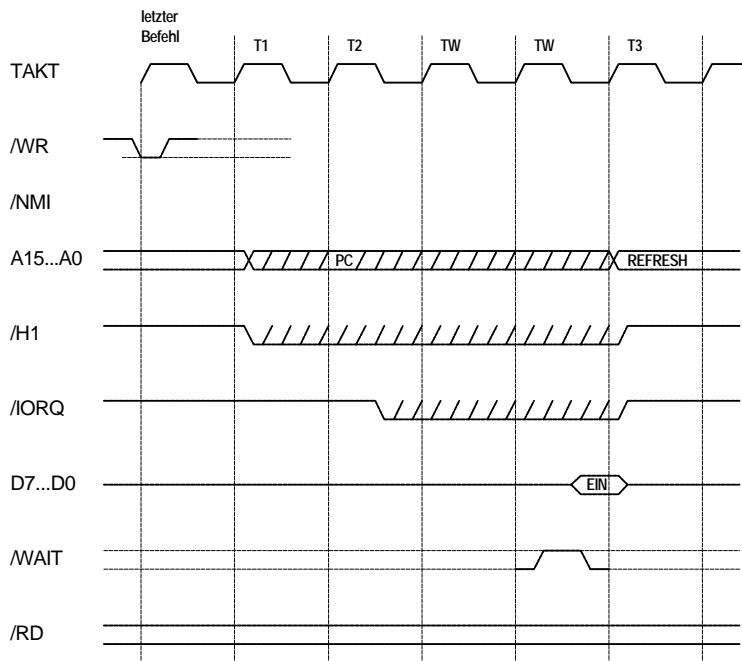

Signale des Interrupt- Anforderungs- und - Annahme - Zyklus

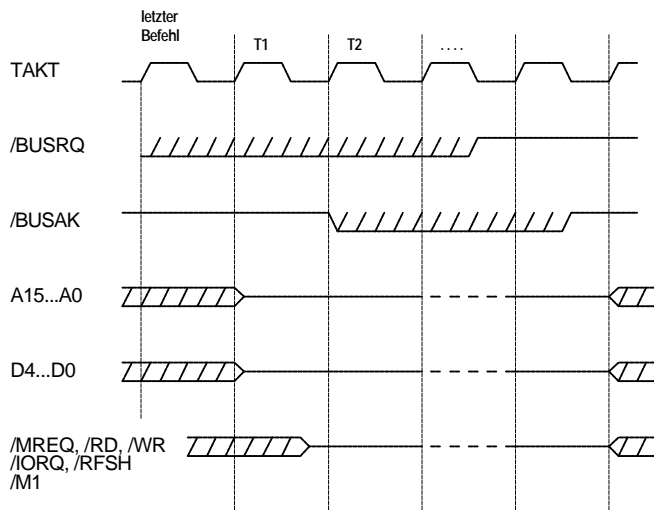

Signale des Bus - Anforderungs- und Annahme - Zyklus

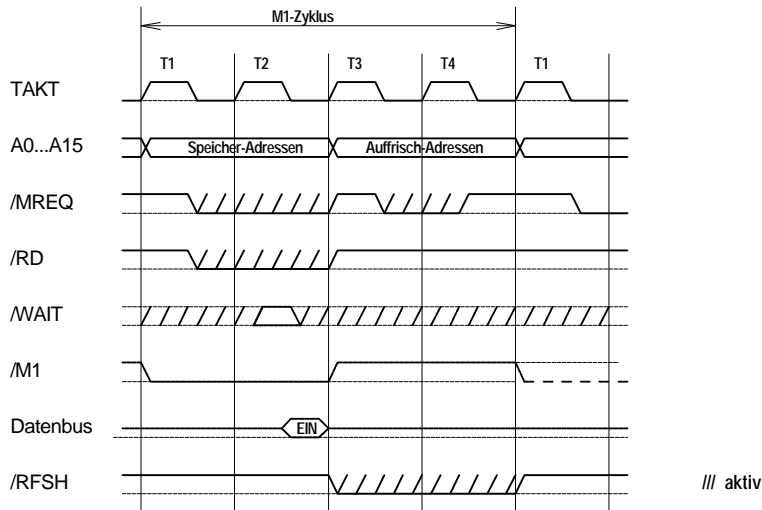

Signale des M1-Zyklus

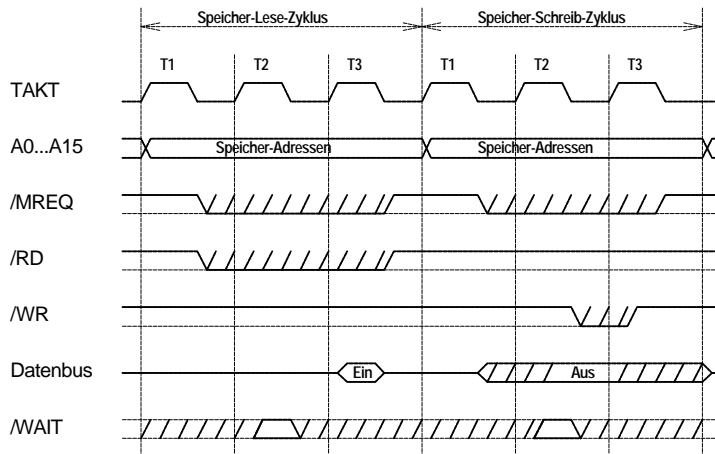

Signale des Daten-Lese- bzw. Daten-Schreib-Zyklus

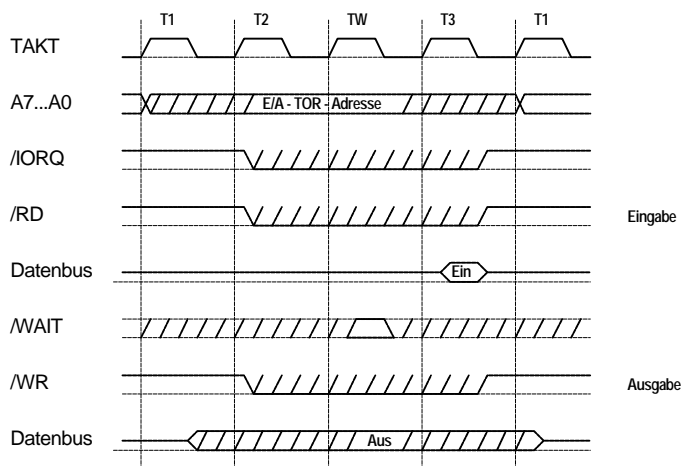

Signale des Daten - E/A - Zyklus

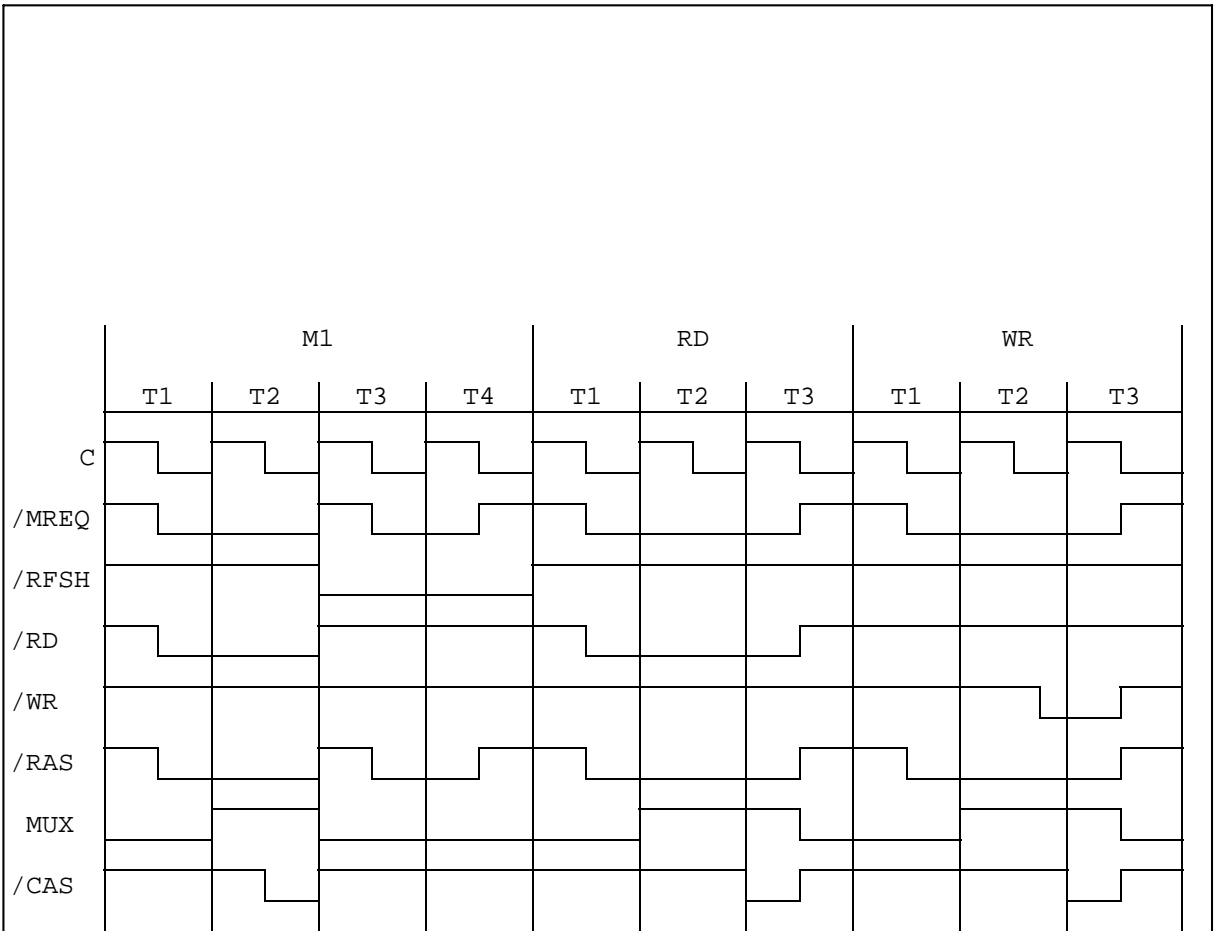

Zeitdiagramm für dynamische Speicher



**ANLAGE 11: REASSEMBLER FÜR U880-BEFEHLE**

\*\*\*\*\*

Da ein Teil der hier wiedergegebenen Anwenderprogramme, der BASIC-Interpreter und das im ROM enthaltene Monitorprogramm in Maschinencode vorliegen, erhalten Sie mit diesem Reassemblerprogramm die Möglichkeit, eine Rückübersetzung in eine U880-Assemblerschreibweise vorzunehmen.

Die Eingabe dieses und der folgenden Programme erfolgt mit dem M-Kommandoanalog der bereits beschriebenen Vorgehensweise (Kontrolle mit Prüfsumme CKS). Der Reassembler steht ab Adresse 3600H bis Adresse 3FE4H. Der Start erfolgt auf der Adresse 3600H. Das Programm meldet sich mit der Ausschrift:

```
ROBOTRON Z 1010 REASS 1.02
```

```
AB  BIS  ORG-ADRESSE:
```

Unter dieser Ausschrift können nun z.B. folgende Adressen eingegeben werden:

```
F000 F020 F000
```

D.h., es wird der Anfang des Monitorprogramms rückübersetzt. Ist die letzte Adresse gleich der ersten, so kann diese entfallen. ORG-Adresse bedeutet die Adresse, auf der das lauffähige Programm stehen müßte. Man kann also auch Programme reassemblieren, die des RAM-Bereiches laufen würden oder auf z.Z. belegten Speicherbereichen lauffähig sind. Sie können z.B. den in Anlage 13 angeführten Zählermodul nicht auf den Originaladressen ab 3C00H reassemblieren, weil dort der Reassembler steht. Wenn Sie das tun wollen, so müssen Sie den Zählermodul einlesen, anschließend mit dem T-Kommando z.B. auf die 1000H umladen und danach den Reassembler einlesen und starten. Kommandos nach dem Einlesen des Zählermoduls:

```
# T 3C00 1000 400      ;Umladen des Zählermoduls
# L 3600 3FFF         ;Einlesen des Reassemblers
# J 3600              ;Starten des Reassemblers
```

```
ROBOTRON Z 1010 REASS 1.02
```

```
AB  BIS  ORG-ADRESSE
1000 1020 3C00
```

Es folgt zeilenweise das reassemblierte Programm (weiter mit Enter). Zu beachten ist, daß der Reassembler auch bei ASCII-Zeichen eine Übersetzung versucht! Daraus können mitunter Verschiebungen entstehen, die dann auch bei richtigen Maschinenbefehlen zu einer falschen Rückübersetzung führen. Nach einigen Bytes fängt sich der Reassembler und arbeitet wieder korrekt. In den meisten nachfolgenden Programmen erfolgt der Abbruch mit S4/K (SHIFT 4/K).

MC-Listing:

```
MPRT /S          3600H/3FEFH

ADDR 00 01 02 03 04 05 06 07 CKS 01234567
      08 09 0A 0B 0C 0D 0E 0F      89ABCDEF
=====
3600 21 73 00 36 00 E7 02 0C 1BF !S.6....
3608 0D 0D 72 6F 62 6F 74 72 2B2 ..ROBOTR
3610 6F 6E 20 5A 20 31 30 31 209 ON Z 101
3618 33 20 72 45 41 53 53 20 1F1 3 REASS
3620 31 2E 30 32 8D E7 02 0D 244 1.02....
```

ADDR	00	01	02	03	04	05	06	07	OKS	01234567	89ABCDEF
	08	09	0A	0B	0C	0D	0E	0F			
3628	0D	41	42	20	20	20	42	49	17B	.AB	BI
3630	53	20	20	4F	52	47	2D	41	1E9	S	ORG-A
3638	44	52	45	53	53	45	3A	0D	20D	DRESSE:	.
3640	8D	E7	10	ED	5B	16	00	E7	3C9	.	L.
3648	03	22	D8	3F	22	E0	3F	E7	364	.	"?"."
3650	08	22	DE	3F	E7	00	7C	B5	35D	.	"?"."
3658	28	03	22	ED	3F	2A	D8	3F	2AD	(	"?"%."
3660	CD	C8	36	78	82	DC	3F	57	3DF	.	.6X2.?"
3668	2D	20	00	22	E2	3F	2A	E0	282	*	+."?"%
3670	3F	E7	07	E7	0E	1E	0D	2A	277	?	.
3678	D8	3F	7E	E7	06	E7	0E	28	39A	.	?^"?"#
3680	1D	1D	1D	15	20	F4	1D	20	1C5	.	.
3688	04	E7	0E	18	F9	CD	85	89	395	.	.
3690	24	D8	3F	16	00	3A	DC	3F	2AC	*	?"."
3698	5F	19	22	D8	3F	2D	E0	3F	2FA	.	"?"%."
36A0	19	22	E0	3F	2A	D8	3F	ED	388	.	"?"%."
36A8	5B	DE	3F	37	ED	52	D2	25	3E5	L	?.?.R.%
36B0	36	E7	01	FE	03	09	00	00	321	6	.
36B8	FE	0D	20	F5	E7	00	10	9D	3BC	.	.
36C0	7E	FE	D0	28	68	FE	ED	CA	59E	.	.
36C8	69	37	FE	7D	28	5F	E6	F0	4F9	J?	.
36D0	FE	40	00	2D	FE	00	38	51	3EA	.	08-."?"
36D8	7E	FE	E7	28	48	E6	3F	FE	4F6	.	.
36E0	0D	28	0E	FE	00	20	3A	FE	2D4	.	(.)"?"
36E8	0B	28	0A	E6	37	FE	13	28	2C3	.	(.)"?"
36F0	34	E0	0F	FE	02	28	2A	FE	379	4	.
36F8	04	28	26	FE	06	20	26	18	1BC	.	(&)"?"
3700	28	7E	E6	0F	FE	01	28	19	2DB	(	^)"?"
3708	7E	E0	37	28	1C	E6	2F	FE	3F2	.	?"(."?"
3710	22	28	0E	E6	0F	0E	0E	FE	281	"	(.)"?"
3718	06	28	0A	18	0C	0E	04	18	086	.	(.)"?"
3720	0A	3E	03	18	06	3E	02	18	0C1	.	>)"?"
3728	02	3E	01	47	09	28	7E	FE	2F0	.	>)"?"
3730	21	28	0A	FE	22	28	E6	FE	45F	(	(.)"?"
3738	36	28	FE	2A	28	DE	FE	FE	46C	6	(.)"?"
3740	2B	28	E2	FE	04	28	D9	FE	467	+	(.)"?"
3748	05	28	D6	FE	0B	28	CE	FE	4F0	5	(.)"?"
3750	7C	28	D2	FE	28	28	CE	FE	488	.	(.)"?"
3758	7D	28	0A	E6	F0	FE	76	28	40B	L	(.)"?"
3760	00	7E	E6	07	FE	06	28	B9	410	.	^)"?"
3768	18	0B	23	7E	FE	00	30	B5	3D7	.	#^)"?"
3770	E6	07	FE	03	28	D7	18	AD	382	.	(.)"?"
3778	7E	E7	00	20	7E	E7	00	20	310	.	^)"?"
3780	7E	E7	00	20	7E	E7	00	20	3D4	.	^)"?"
3788	0E	C9	48	41	4C	54	4C	44	290	.	.HALTLD
3790	20	20	41	44	44	20	41	44	18E	.	.ADD AD
3798	48	20	53	55	42	20	53	42	202	C	.SUB SB
37A0	48	20	41	4E	44	20	58	4F	1FD	C	.AND XO
37A8	52	20	4F	52	20	20	43	4D	1E3	R	.OR CM
37B0	50	20	50	55	48	50	4F	4F	24F	P	.PUSHPO
37B8	50	20	52	53	54	20	4A	4D	220	P	.RST JM
37C0	50	20	45	50	58	20	4F	55	229	P	.EXX OU
37C8	54	20	49	4E	20	20	45	58	1E8	T	.IN EX
37D0	26	20	45	53	20	20	44	49	1AA	.	.EX DI
37D8	20	20	45	49	20	20	20	53	189	.	.EI IS
37E0	50	29	2C	48	4C	00	44	45	1C2	P	.HL DE
37E8	2C	48	4C	00	58	50	2C	48	1D7	.	.HL SP,H
37F0	4C	00	49	4E	48	20	44	45	1CF	L	.INC DE
37F8	48	20	52	4C	43	41	52	52	229	C	.RLOARR
3800	43	41	52	4C	41	20	52	52	227	.	.CARLA RR
3808	41	20	44	41	41	20	48	50	1DA	A	.DAA CP
3810	4C	20	53	49	46	48	48	48	1EE	L	.SCF CC
3818	46	20	4E	4F	50	20	45	58	215	F	.NOF EX
3820	41	46	44	49	4E	59	49	52	259	.	.AFDUNZJR
3828	20	20	4A	52	4E	59	49	52	220	.	.JRNZJR
3830	5A	20	4A	52	4E	43	4A	52	243	Z	.JRNZJR

ADDR	00	01	02	03	04	05	06	07	OKS	01234567	89ABCDEF
	08	09	0A	0B	0C	0D	0E	0F			
0000	40	20	20	42	40	20	20	44	1A5	C	(BC) (D
0040	45	20	52	40	40	20	52	52	213	E)RLC	RR
0048	40	20	52	40	20	20	52	52	1E5	C	RL RR
0050	20	20	53	40	41	20	53	52	1E5		SLA SR
0058	41	20	53	40	40	20	53	52	211	A	SLL SR
0060	40	20	42	40	40	20	52	45	202	L	BIT RE
0068	50	20	53	45	54	20	20	53	1FA	S	SET IS
0070	50	20	20	20	20	20	4E	45	18C	P)	NE
0078	47	20	52	45	54	4E	49	4D	236	G	RETNIM
0080	20	30	52	45	54	40	49	4D	21A		GRETIIM
0088	20	31	20	20	20	20	49	4D	167	1	IM
0090	20	02	52	52	44	20	52	4C	1F8		2BRD RL
0098	44	20	49	20	41	20	52	2C	1B8	D	I, A R,
00A0	41	20	41	20	49	20	41	2C	1A4	A	A, I A,
00B0	52	20	4C	44	49	20	43	50	1FE	R	LDI CP
00B8	40	20	40	4E	49	20	4F	55	20D	I	INI OU
00C0	54	49	4C	44	49	52	43	56	25B	T	LDIRCP
00C8	40	52	49	4E	49	52	4F	54	270	I	RINIROT
00D0	40	52	4C	44	44	20	43	56	222	I	RLDD CP
00D8	44	20	49	4E	44	30	4F	55	203	D	IND OU
00E0	54	44	4C	44	44	52	43	50	251	T	LDLDDROP
00E8	44	52	49	4E	44	52	4F	54	266	D	RINDROT
00F0	44	52	20	4F	55	54	43	48	239	D	R OUTCH
00F8	40	41	52	20	4C	52	20	20	1D4	C	AR LR
0100	0B	27	05	0F	7C	0E	00	67	397	.'.	0>..G
0108	7E	E7	06	23	7E	E7	08	E7	46C	^.	..#>..
0110	00	09	21	00	09	10	E9	21	268	..!	#9..!
0118	00	09	10	E4	21	00	09	10	215	09.	!;9.
0120	0F	21	4E	09	10	DA	21	5D	2F4	..!	K9..!1
0128	00	10	05	42	00	40	00	44	1EF	9.	..B.C.D
0130	00	45	00	40	00	4C	00	4D	126	..E.	H.L.M
0138	00	41	00	42	43	44	45	46	197	..A.	BCDEH
0140	4C	41	46	4E	50	50	20	4E	243	L	AFNZZ N
0148	40	40	20	50	4F	50	45	20	229	C	C POPEP
0150	20	4D	20	20	52	45	54	4A	1E2	M	RETJ
0158	50	40	52	40	41	4C	4C	2D	235	P	JRCALL-
0160	20	41	2C	40	41	42	43	44	106	#A,	ABCD
0168	45	40	4C	53	50	D9	C9	FD	41B	E	HLSF...
0170	7E	06	E6	00	0F	0F	0F	E6	2AF	^	..8
0178	07	C9	0D	67	09	0F	E6	00	305	..	..G9..
0180	09	70	E7	06	70	E7	06	C9	45D	..X.	..Y..
0188	0E	C2	E7	00	C9	D9	FD	2A	41A	>	..*..
0190	00	0F	FD	7E	00	FE	40	DA	400	..?	..^..0..
0198	0E	30	FE	00	30	06	FE	C0	3C3	..	..8..
0200	0E	2A	10	42	FE	70	20	10	273	0#.	..B.V(.
0208	21	0E	07	0C	70	07	0D	67	396	!	..7.X7.G
0210	00	0D	0A	09	3E	2C	E7	00	290	9.	..9>..
0218	FD	7E	06	E6	07	0D	0A	09	378	..^	..9
0220	00	65	09	21	09	07	0D	70	308	..E	9!..7.X
0228	07	C0	65	09	00	0E	0F	21	2E6	7.	E9.0.!
0230	92	07	05	6F	7C	0E	00	67	38E	..7.	0>..G
0238	0D	70	07	FD	7E	00	E6	07	3E4	..X	7.^..
0240	0D	0A	09	C0	65	09	FE	00	400	..	..9.E9..
0248	0F	70	3C	FE	0D	C0	7C	3C	359	..V	<..<..
0250	FE	ED	0A	E0	0E	FE	FD	C0	600	..	..>..
0258	00	3D	0C	0D	0A	60	3A	E6	45A	=.	..H..
0260	07	0A	7E	0A	FE	00	20	35	2EB	..	..<5
0268	FE	07	20	40	FE	04	C0	70	304	..	..(K...P
0270	00	FE	02	0A	0D	00	FD	7E	446	..	..<..
0278	00	E0	0F	FE	01	20	16	FE	330	..	..(..
0280	05	20	00	C0	01	09	21	02	201	..	..(..!..
0288	07	0D	70	07	0D	00	09	02	3F8	7.	X7.R9
0290	0F	09	C0	65	09	21	E6	37	2B7	..9.	E9!..7
0298	0D	70	07	10	EF	FD	7E	00	3FE	..X	7.^..
0300	E6	00	0F	21	92	07	05	6F	300	..8.	!..7.0
0308	7C	0E	06	67	0D	70	07	FD	42A	>	..6.X7.

ADDR	00	01	02	03	04	05	06	07	OKS	01234567
	08	09	0A	0B	0C	0D	0E	0F		89ABCDEF
3A48	7E	01	E7	06	03	65	39	21	2EE	^
3A50	0A	37	0D	78	37	0D	72	39	3EE5	.7.X7.R9
3A58	06	30	E7	09	FD	7E	00	E6	48E	.0..^.
3A60	08	06	36	E7	06	03	65	39	346	.0..E9
3A68	21	58	39	0D	78	37	18	21	262	!89.X7.!.
3A70	3E	04	0D	19	39	0D	67	39	20E	>..9.G9
3A78	0D	14	39	E7	0E	18	12	3E	277	>..9.>
3A80	00	0D	19	39	0D	67	39	0D	359	..9.G9.
3A88	14	39	03	65	39	3E	02	18	206	.9.E9>..
3A90	E1	FD	4E	01	FD	46	02	ED	45F	..M..F..
3A98	48	DA	3F	0D	79	39	03	65	468	C.?.Y9.E
3AF0	39	11	00	00	E6	07	TE	08	238	9..
3AF8	20	33	0D	67	39	FD	21	BE	394	8.E9.!.
3AB0	37	0D	34	3F	D9	F1	TE	06	43F	7.4?>
3AB8	28	D7	TE	04	08	09	28	0F	279	(...8.(.
3AC0	FE	05	28	14	03	65	39	FD	39D	..(..E9.
3AC8	7E	01	E7	06	03	65	39	21	2EE	>..E9!
3AD0	DE	37	0D	08	0F	03	65	39	452	.7.??.E9
3AD8	21	E6	37	18	FD	72	39	303	!.7..R9	
3AE0	28	11	TE	02	38	18	28	19	103	(...8.(.
3AE8	21	0E	37	0D	78	37	21	EC	36F	!.7.X7!.
3AF0	37	18	0F	21	48	39	0D	78	318	7.JK9.X
3AF8	37	03	65	39	21	02	37	18	203A	7.E9!.7.
3B00	F5	21	0E	37	0D	78	37	0E	305	!.7.X7>
3B08	4D	E7	00	03	65	39	E6	0F	389	M..E9.
3B10	FE	03	28	23	TE	08	28	2E	2AB	..(#..(.
3B18	E6	07	28	58	TE	02	DA	37	3F1	..(T...#
3B20	38	0A	E6	38	TE	05	38	28	384	..8#
3B28	28	35	TE	07	38	31	21	FA	2E1	(0..8!.
3B30	37	0D	67	39	03	64	3F	21	2FB	7.G9.4?!
3B38	FD	37	37	78	37	0D	72	39	41D	.7.X7.R9
3B40	02	1E	39	03	65	39	21	F6	39C	.9.E9!
3B48	37	18	EF	21	F2	37	0D	78	30D	7?..!.7.X
3B50	37	0D	67	39	0D	09	39	08	377	7.G9..9.
3B58	07	39	21	F6	37	18	EF	21	314	E9!.7..!
3B60	0E	37	0D	78	37	0D	67	39	3AE	.7.X7.G9
3B68	0D	09	39	3E	2C	E7	00	FD	35E	..9>..
3B70	7E	01	E7	06	03	65	39	21	2EE	>..E9!
3B78	19	38	0D	01	08	D9	0D	67	398	..8.1!..G
3B80	39	TE	02	DA	05	39	TE	47	397	9..E9.G
3B88	FD	4E	01	08	79	28	01	05	2BE	..M..Y!.
3B90	21	E6	37	0D	E5	01	08	08	2FE	*.?.>
3B98	FD	48	DA	3F	0D	79	39	3E	486	.C.?.Y9>
3BA0	06	0D	19	39	03	65	39	0D	358	..9.E9.
3BA8	67	39	0B	47	28	14	0F	E6	2E9	G9.G!..
3BB0	00	F5	21	92	37	0D	78	37	35E	..!.7.X7
3BB8	3E	02	0D	0F	39	3E	2C	E7	2AB	>..9>..
3BC0	00	F1	0D	1E	39	03	65	39	376	..9.E9
3BC8	0F	E6	37	F5	21	0E	37	0D	398	..!.7.
3BD0	78	37	F1	0D	1E	39	3E	2C	32E	X7..9>.
3BD8	E7	00	FD	4E	01	FD	46	02	378	..M..F.
3BE0	0D	79	39	03	65	39	21	0E	38F	.Y9.E9!.
3BE8	37	0D	78	37	0D	67	39	TE	41E	7.X7.C9.
3BF0	04	36	34	F7	28	23	TE	02	254	.04.(#..
3BF8	28	19	36	0E	0E	07	0D	19	1B3	(.8.>..
3C00	39	21	3E	38	0D	78	37	03	38F	9!>8.X7.
3C08	65	39	3E	07	0D	19	39	21	223	E9>..9!
3C10	39	38	18	F8	21	0E	38	18	229	:8..!>8.
3C18	08	21	3A	38	0D	78	37	3E	250	..!;8.X7>
3C20	58	0D	19	39	03	65	39	FD	385	..3.E9.
3C28	46	02	FD	4E	01	0D	67	39	381	F..M..G9
3C30	D6	04	28	34	57	TE	02	28	2A5	..(#..(.
3C38	2E	35	16	3E	02	0F	39	103	.0.>...9	
3C40	0D	06	39	3E	28	E7	06	0D	3A8	..9>(...
3C48	79	39	3E	29	E7	00	03	65	328	Y9>)...E
3C50	39	3E	07	0D	0A	39	18	F8	28E	9>...9..

ADDR	00	01	02	03	04	05	06	07	OKS	01234567
	08	09	0A	0B	0C	0D	0E	0F		89ABCDEF
3058	CD	43	3C	D9	CD	80	39	3E	3E9	.C<...9>
3060	02	CD	0F	39	03	65	39	CD	345	...9.E9.
3068	43	3C	D9	CD	80	39	3E	07	323	C<...9>.
3070	CD	0A	39	03	65	39	FD	23	391	...9.E9.#
3078	FD	7E	06	FE	46	80	12	21	31C	..^...00.!>
3080	42	38	CD	81	38	D9	FD	7E	487	B8.1;...^
3088	00	E6	07	CD	0A	39	03	65	325	...9.E
3096	09	FE	38	38	0E	FE	C6	38	3F3	9...8...8
3098	05	21	0A	38	18	00	21	06	16F	..!J8..!F
30A0	38	18	03	21	62	38	CD	78	258	8..!B8.X
30A8	37	CD	37	39	06	80	E7	00	381	7.G9.0..
30B0	3E	C2	E7	00	FD	7E	00	E6	382	>...^..
30B8	07	CD	0A	39	03	65	39	3E	286	...9.E9>
30C0	28	E7	06	3E	49	E7	06	79	2F6	(...>1..Y
30C8	E7	00	3E	28	0B	78	28	00	2C3	..>+X(.
30D0	3C	3C	E7	00	78	2F	18	08	221	<<...X/>
30D8	E7	00	78	E7	06	3E	29	E7	39A	..X...>).
30E0	08	C9	78	E7	00	79	E7	00	38A	..Z...Y..
30E8	C9	3E	49	18	F6	3E	48	18	2FC	..>I...>H.
30F0	F2	3E	4C	18	EE	E7	0E	3E	385	..>L...>
30F8	2C	E7	06	C9	0E	58	18	02	25C	...X..
3D00	0E	59	FD	28	FD	7E	00	FD	3FF	..Y.#.^..
3D08	46	01	FE	78	CA	65	39	FE	421	F...V.E9.
3D10	40	DA	7E	8D	FE	80	DA	C2	566	@...=....
3D18	3D	FE	C0	DA	9C	8D	FE	CB	577	=...=...
3D20	28	62	FE	E1	28	13	FE	E3	485	(B...(...
3D28	28	1F	FE	E5	28	18	FE	E9	449	(...(...
3D30	28	2B	FE	F9	28	3A	C3	65	3D4	(+...(...E
3D38	39	21	B6	37	18	53	21	B2	235	9!..7...!
3D40	37	CD	78	37	CD	E9	3C	18	38D	7.X7...<
3D48	2D	21	CE	37	CD	78	37	21	389	..!..7.X7!
3D50	6E	38	CD	78	37	CD	F5	3C	426	N8.X7...<
3D58	CD	E9	3C	18	D9	21	BE	37	3F9	..<...!..7
3D60	CD	78	37	3E	28	E7	00	CD	396	..X7>(...
3D68	E9	3C	3E	29	E7	00	18	C6	351	!..<...)
3D70	21	8E	37	CD	78	37	3E	08	2A3	!..7.X7>..
3D78	CD	1E	39	3E	2C	E7	00	CD	342	..9>...)
3D80	E9	3C	18	B2	F4	28	FD	7E	48A	..<...#..
3D88	01	E6	07	FE	06	C2	65	39	352	...E9
3D90	CD	76	3C	CD	80	39	CD	BF	491	..V<...9..
3D98	3C	C3	65	39	21	92	37	CD	354	<.E9!..7.
3DA0	01	38	D9	FD	7E	00	E6	07	3AD	1;...^...)
3DA8	FE	04	28	9C	FE	05	28	0D	26E	..!...!
3DB0	FE	06	CC	BF	3C	C3	65	39	42C	...<.E9
3DB8	CD	ED	3C	18	78	CD	F1	3C	580	..<...<
3DC0	18	78	21	0E	07	CD	78	07	36D	..!..7.X7
3DC8	CD	67	39	FE	06	28	58	CD	36E	..G9...!
3DD0	0A	39	CD	67	39	18	06	CD	298	..9.G9...)
3DD8	BF	3C	CD	80	39	FD	7E	00	3FC	..<...9.^.
3DE0	E6	07	FE	06	28	06	CD	0A	2F6	...!
3DE8	39	C3	65	39	CD	80	39	CD	3ED	9.E9...9.
3DF0	BF	3C	C3	65	39	E6	0F	FE	44F	..<.E9...)
3DF8	09	CA	C3	3E	FD	7E	00	FE	452	...>^..
3E00	21	DA	65	39	CA	80	3E	E6	437	!..E9...>.
3E08	0F	FE	06	CA	34	3E	FE	08	3C5	...>...)
3E10	CA	9F	3E	E6	07	FE	04	28	3BE	..>...!
3E18	6E	FE	06	28	65	21	8E	37	2E4	N...!E!..7
3E20	CD	78	37	FD	7E	00	FE	22	417	..X7.^..."
3E28	28	49	FE	26	28	28	FE	2A	38E	(J.&!(.#
3E30	28	29	FE	2E	28	14	FE	36	2E4	()...!...6
3E38	28	19	CD	BF	3C	80	39	387	...<...9	
3E40	FD	7E	02	E7	06	18	9C	CD	3EB	..^...^
3E48	F1	3C	3E	2C	E7	06	FD	7E	3F9	..<...^
3E50	01	E7	06	C3	65	39	CD	ED	489	...E9..
3E58	3C	18	EF	CD	E9	3C	CD	80	482	<...<..
3E60	39	3E	28	E7	06	FD	4E	01	2D2	9>(...N.

ADDR	00	01	02	03	04	05	06	07	CKS	01234567
	08	09	0A	0B	0C	0D	0E	0F		89ABCDEF
3FE68	FD	46	02	0D	79	39	3E	29	32B	.F..Y9>)
3FE70	E7	08	18	0F	05	0D	61	3E	48F	.....A>
3FE78	D9	C1	0D	88	39	0D	E9	3C	512	.....9..<
3FE88	18	D1	21	F6	37	18	03	21	273	..!..7..!
3FE88	F2	37	0D	78	37	FD	7E	08	428	.?.X7.^.
3FE98	FE	27	0A	E8	8D	FE	38	0A	4FC	.'.=.0.
3FE98	BD	3D	0D	BF	3C	18	E4	21	3AF	.=...<..!
3EA08	F6	37	18	03	21	F2	37	0D	35F	.7..!..7.
3EA08	78	37	0D	E9	3C	03	65	39	482	X7..<.E9
3EE88	21	8E	37	0D	78	37	0D	E9	418	!..7.X7..
3EE88	3C	3E	2C	E7	08	FD	4E	01	2D9	<.....N.
3EEC8	FD	46	02	0D	79	39	18	0B	367	.F..Y9..
3EEC8	21	92	37	0D	78	37	0D	E9	41C	!..7.X7..
3ED88	3C	3E	2C	E7	08	0D	72	39	385	<.....R9
3ED88	FE	02	28	06	0D	1E	39	03	315	..(!...9.
3EE88	65	39	0D	E9	3C	03	65	39	3F1	E9..<.E9
3EE88	FD	23	7D	7E	08	FE	88	D2	4EB	.#.^.^.....
3EFA8	9E	3F	7E	48	0A	65	39	E6	489	.?.E.E9.
3EFA8	07	28	5B	7E	01	28	6F	FD	31D	.(I..(0.
3F088	7E	08	E6	0F	7E	03	CA	8F	3CD	^.....
3F088	3F	0A	78	3F	7E	0A	28	68	363	?..S?..(H
3F188	FE	08	0A	9E	3F	FD	7E	08	428	.....?..^.
3F188	FE	68	38	24	E6	07	FE	07	3A4	.00\$.....
3F288	28	26	0D	67	39	47	E6	01	2E9	(%.G9G..
3F288	4F	04	FD	7E	08	E6	03	88	337	0..^.....
3F388	81	21	72	38	07	07	16	08	178	.!R8.....
3F388	5F	19	0D	78	37	03	65	39	355	..X7.E9
3F488	E6	08	0F	21	92	38	18	EE	2EE	.7..!..8.
3F488	21	8E	37	0D	78	37	0D	67	396	!..7.X7.G
3F588	39	21	9A	88	18	DE	21	CA	38D	9!..8..!
3F588	37	0D	78	37	0D	67	39	FE	41E	.?.X7.G9.
3F688	86	28	05	0D	0A	39	18	D5	238	.(...9..
3F688	8E	46	E7	08	18	0F	21	06	339	>F.....!
3F788	37	18	E6	21	9E	37	18	03	246	.7..!..7..
3F788	21	96	37	0D	78	37	3E	02	2AA	!..7.X7>.
3F888	0D	0F	39	3E	2C	E7	08	0D	333	..9>.....
3F888	72	39	0D	1E	39	18	FE	21	286	R9..9..!
3F988	8E	37	0D	78	37	0D	61	3E	3AD	.?.X7.M>
3F988	D9	0D	88	39	18	E9	21	8E	48F	.....9..!
3FA88	37	0D	78	37	0D	87	3F	D9	41F	.?.X7..?.
3FA88	0D	88	39	03	61	3E	FE	A8	486	..9..A>.
3FB88	0A	65	39	7E	BC	D2	65	39	4A2	.E9.....E9
3FB88	E6	07	7E	04	D2	65	39	FD	45C	.....E9.
3FC88	7E	08	FE	88	38	07	06	04	388	^.....8..
3FC88	E6	0F	21	AA	88	03	34	3F	32E	..!..8..4?
3FD88	7E	07	08	E7	08	28	18	F8	417	^.....#..
3FD88	FF	FF	FF	FF	FF	FF	FF	FF	7FB	.....
3FE88	08	08	08	08	08	08	08	08	888	.....
3FE88	08	08	08	08	08	08	08	08	888	.....

ANLAGE 12: BASIC-Interpreter (MC-Listing)

\*\*\*\*\*

Speicherbereich: 100H - BA6H, Start: 100H, Restart: 103H

Beachte:

Bei Benutzung einer größeren Alpha-Tastatur ist bei der INPUT-Anweisung keine Umschaltung (HEXUM/ALPHA) erforderlich. Deshalb sind im BASIC die 3 Speicherplätze ab Adresse 43BH (CD 12 01) und ab Adresse 443H (CD 15 01) auf Null (00 00 00) zu setzen!

ADDR	00	01	02	03	04	05	06	07	CKS	01234567
	08	09	0A	0B	0C	0D	0E	0F		89ABCDEF
0100	C3	AF	07	C3	BB	01	E7	00	3DF	.....
0108	C9	E7	01	C9	E7	08	C9	E7	519	.....
0110	09	C9	E7	12	C9	E7	13	C9	457	.....
0118	7C	BA	C6	7D	EB	C9	1A	FE	58F	\..1....
0120	20	C8	13	13	F9	F1	CD	1B	3DD	.....
0128	06	C3	36	06	CD	1E	01	D6	2C7	..6.....
0130	40	D3	20	1B	13	CD	75	05	2AD	0.....U.
0138	29	DA	9D	01	D5	EB	CD	B6	4E4	).....*
0140	05	CD	18	01	DA	66	06	2A	25B	.....F.*
0148	4C	11	CD	D3	05	D1	C9	FE	49F	L.....
0150	1B	3F	D8	13	21	15	11	07	193	..?..1...
0158	05	6F	3E	00	0C	67	C9	E3	3D1	..0>..G..
0160	CD	1E	01	BE	23	28	08	D5	2D2	.....#(..
0168	5E	23	56	EB	D1	13	01	13	2BF	^#V.....
0170	23	23	E3	C9	21	00	00	44	257	##..!..D
0178	CD	1E	01	FE	30	D8	FE	3A	42A	.....0..:
0180	D0	3E	F0	A4	20	17	04	C5	3A2	..>.....
0188	44	4D	29	29	09	29	1A	13	142	DM))..)
0190	E6	0F	85	6F	3E	00	0C	67	31A	.....0>..G
0198	C1	1A	F2	7B	01	D5	11	A4	3D3	...[.....
01A0	01	C3	3A	06	48	4F	57	3F	231	...:HOW?
01A8	0D	52	45	41	44	59	0D	57	1E6	..READY.W
01B0	48	41	54	3F	0D	53	4F	52	21D	HAT?.SOR
01B8	52	59	0D	31	13	11	CD	15	1EF	RY.1.....
01C0	01	11	A9	01	97	CD	C3	06	2E9	.....
01C8	21	D4	01	22	0B	10	3E	FF	270	!..".>..
01D0	32	02	10	21	00	00	22	13	09A	2..!.."
01D8	10	22	0D	10	3F	3E	CD	6C	204	..".>..L
01E0	06	05	ED	5B	4E	11	CD	74	3C3	...[N..T
01E8	01	CD	1E	01	7C	B5	C1	CA	3A9	.....\..:
01F0	34	09	1B	7C	12	1B	7D	12	190	4..\/..1.
01F8	C5	D5	73	93	F5	CD	9C	06	58A	..Y.....
0200	D5	20	10	D5	CD	B9	06	C1	427	.....
0208	2A	1F	10	CD	55	07	60	69	24B	*...U..0I
0210	22	1F	10	C1	2A	1F	10	F1	25C	.....*..:
0218	E5	FE	03	CA	BB	01	85	6F	460	.....0..:
0220	3E	00	0C	67	ED	5B	4C	11	2D6	>..G..L.
0228	CD	13	01	D2	66	06	22	1F	265	.....F..:
0230	10	D1	CD	5F	07	D1	E1	CD	493	.....
0238	55	07	C3	DC	01	CD	30	06	2FF	U..7.....0.
0240	21	52	11	22	1F	10	CD	30	1D2	!R..".0..:
0248	06	C3	BB	01	CD	30	06	11	299	.....0..:
0250	52	11	21	00	00	CD	A4	06	1FB	R..!.....
0258	DA	EB	01	ED	53	0B	10	13	304	.....S..:
0260	13	CD	86	0B	21	37	08	C3	294	.....17..:
0268	37	09	CD	77	04	D5	CD	30	35A	7..W...0..:
0270	06	CD	9C	06	C2	9E	01	F1	3C7	.....
0278	C3	5B	02	CD	74	01	CD	30	35F	..L..T...0

ADDR	00	01	02	03	04	05	06	07	OKS	01234567
	08	09	0A	0B	0C	0D	0E	0F		89ABCDEF
02800	06	7C	B5	28	05	3E	14	32	1E8	. \. (.) > . 2
02808	02	10	CD	9C	06	DA	BB	01	317	.....
02810	CD	40	07	CD	06	0B	3A	02	2AE	. @. ....
02818	10	3D	32	02	10	CA	EB	01	217	. =2. ....
02820	CD	04	06	18	E8	0E	06	CD	358	.....
02828	5F	01	0B	E1	02	CD	E5	07	307	.....
02830	C3	61	02	CD	5F	01	0D	ED	31D	. -A. ....
02838	02	CD	E5	07	C3	52	02	CD	39F	.....
02840	5F	01	28	C9	02	CD	77	04	296	. #. ....
02848	4D	18	05	CD	D0	06	18	11	286	M. ....
02850	CD	5F	01	2C	D9	02	CD	1B	31C	.....
02858	06	18	E4	CD	E5	07	CD	25	3AD	.....%
02860	01	CD	77	04	C5	CD	00	07	2E2	.....M
02868	C1	18	E5	CD	87	07	CD	77	45D	.....M
02870	04	D5	CD	9C	06	C2	9E	01	3A9	.....
02878	2A	0B	10	E5	2A	0D	10	E5	256	*. ....
03000	21	00	06	22	13	10	39	22	0C1	!.....9"
03008	0D	10	C3	5B	02	CD	30	06	240	.....I..0
03010	2A	0D	10	7C	E5	CA	36	06	27E	*. ....6.
03018	F9	E1	22	0D	10	E1	22	0B	327	...../..6.
03020	10	D1	CD	6C	07	CD	25	01	314	.....L..%
03028	CD	78	07	CD	01	06	2B	22	27C	.....+.."
03030	13	10	21	04	09	C3	37	09	154	.....!..7.
03038	CD	77	04	22	17	10	21	0C	1BE	.M..!..!
03040	09	C3	37	09	CD	77	04	18	26C	..7..W.
03048	03	21	01	00	22	15	10	2A	096	!.....*
03050	0B	10	22	19	10	EB	22	1B	18E	.....
03058	10	01	0A	00	2A	18	10	EB	153	.....*
03060	00	63	39	3E	09	7E	23	E6	29F	BM9>..>#.
03068	20	18	7E	2B	BA	20	F5	7E	386	(.^+..^
03070	BB	20	F1	EB	21	00	00	39	311	.....!..9
03078	44	4D	21	0A	00	19	CD	5F	201	DM!.....
03080	07	F9	2A	18	10	EB	CD	25	382	.....%..
03088	01	CD	2C	01	DA	06	06	22	233	.....6.."
03090	0F	10	D5	EB	2A	18	10	7C	2A8	.....*/..
03098	05	CA	37	06	CD	18	01	28	2CA	.....7..*
03100	09	D1	CD	6C	07	2A	0F	10	263	.....L..*
03108	18	E8	5E	23	56	2A	15	10	226	.....^#V*
03110	E5	7C	AA	7A	19	FA	BC	08	457	...../..N..
03118	0C	FA	DF	03	EB	2A	18	10	3C0	.....*
03120	73	23	72	2A	17	10	F1	E7	301	S#R*.....
03128	F2	CC	08	EB	CD	F7	05	D1	546	.....
03130	38	0F	2A	19	10	22	08	10	0D7	0..*.."
03138	2A	18	10	EB	CD	25	01	E1	314	*. ....%
03140	D1	CD	6C	07	CD	25	01	21	325	..L..%..I
03148	00	00	18	03	CD	77	04	7C	1DF	.....W..
03150	B5	D2	61	02	CD	BB	06	D2	43A	.....A..
03158	5B	02	C3	BB	01	2A	11	10	227	L.....*
04000	F9	E1	22	0B	10	D1	D1	D5	48E	....."
04008	CD	D0	06	18	08	CD	2C	01	2BD	.....
04010	DA	57	04	13	12	D5	CD	2C	32D	.M.....
04018	01	DA	36	06	1A	4F	97	12	229	..6..0..
04020	D1	CD	C3	06	79	18	12	D5	3E2	.....Y..
04028	EB	24	0E	10	E5	21	07	04	241	*. ....!
04030	22	0B	10	21	00	00	39	22	0B9	"..!..9"
04038	11	10	D5	CD	12	01	3E	3A	24E	.....>:L
04040	CD	6C	06	CD	15	01	ED	5B	38A	.....L
04048	4E	11	CD	77	04	D1	EB	78	3D6	N..W..S
04050	23	72	E1	22	0B	10	D1	F1	375	#R.."
04058	CD	5F	01	2C	5F	04	C3	07	286	.....
04060	04	CD	25	01	1A	FE	0D	28	244	..%..I..
04068	0B	CD	01	06	CD	5F	01	2C	233	.....
04070	72	04	18	F5	CD	25	01	CD	343	W.....%
04078	0F	04	E5	21	16	09	C3	07	2E2	.....!..7
04080	09	CD	AA	04	D8	6F	C9	CD	461	.....0..



ADDR	00	01	02	03	04	05	06	07	OKS	01234567	89ABCDEF
	08	09	0A	0B	0C	0D	0E	0F			
0488	AA	04	C8	6F	C9	CD	AA	04	429	...	0...
0490	C8	D8	6F	C9	CD	AA	04	6F	4C2	...	0...
0498	C8	D8	6C	C9	CD	AA	04	C8	519	...	L...
04A0	6F	C9	CD	AA	04	D8	6F	C9	4BB	0...	...
04A8	E1	C9	79	E1	C1	E5	C5	4F	5BE	...	Y...
04B0	CD	6F	04	EB	E3	CD	F7	05	527	...	...
04B8	D1	21	00	00	3E	01	C9	CD	2C7	...	!
04C0	5F	01	2D	C8	04	21	00	00	17A	...	!
04C8	18	2A	CD	5F	01	2B	CE	04	26C	...	*
04D0	CD	FD	04	CD	5F	01	2B	EC	412	...	+
04D8	04	E5	CD	FD	04	EB	E3	7C	501	...	+
04E0	AA	7A	19	D1	FA	D3	04	BC	48B	...	2
04E8	F2	D3	04	C3	9D	01	CD	5F	456	...	...
04F0	01	CD	82	05	E5	CD	FD	04	36	...	...
04F8	CD	E2	05	18	E0	CD	5F	05	3DD	...	...
0500	CD	5F	01	2A	2D	05	E5	CD	38B	...	*
0508	5F	05	06	00	CD	DF	05	E3	2FE	...	...
0510	CD	DF	05	EB	E3	7C	B7	28	4DA	...	...
0518	06	7A	B2	EB	C2	9E	01	7D	3FB	...	Z
0520	21	00	00	B7	28	28	19	DA	21E	!	...
0528	9E	01	3D	20	F9	18	22	CD	2FC	...	=
0530	5F	01	2F	82	05	E5	CD	5F	327	...	/
0538	05	06	00	CD	DF	05	E3	CD	36C	...	...
0540	DF	05	EB	E3	EB	7A	B3	CA	594	...	...
0548	9E	01	C5	CD	C3	05	60	69	3C2	...	...
0550	C1	D1	7C	B7	FA	9D	01	78	4D5	...	...
0558	B7	FC	E2	05	C3	00	05	21	38B	...	...
0560	C3	08	C3	87	09	CD	2C	01	2C8	...	7
0568	38	05	7E	23	66	6F	C9	CD	349	8.	#FD
0570	74	01	78	B7	00	CD	5F	01	391	T.	X
0578	28	83	05	CD	77	04	CD	5F	324	(	...
0580	01	29	83	05	C9	C3	36	06	27A	(	...
0588	21	04	10	ED	5F	ED	6F	28	300	!	...
0590	ED	6F	CD	75	05	7C	B7	FA	4D0	0.	U
0598	9D	01	B5	CA	9D	01	D5	C5	455	...	...
05A0	EB	2A	04	10	ED	52	36	FC	394	*	...
05A8	19	23	C1	09	CD	75	05	05	3DE	#	...
05B0	18	CD	DF	05	13	C9	2A	1F	2F1	...	...
05B8	18	D5	EB	2A	4C	11	CD	D8	3FC	...	...
05C0	05	D1	C9	E5	6C	26	00	CD	3E3	...	...
05C8	CE	05	41	7D	E1	67	0E	FF	3E6	...	...
05D0	0C	CD	D8	05	30	FA	19	C9	3C2	...	...
05D8	7D	93	6F	7C	9A	67	C9	7C	441	!	...
05E0	B7	FD	7C	52	C8	7C	F5	2F	540	!	...
05E8	67	7D	2F	6F	23	F1	BC	F2	484	!	...
05F0	9D	01	78	EE	00	47	C9	7C	410	...	...
05F8	AA	F2	FD	05	EB	CD	10	01	46F	...	...
0600	C9	CD	2C	01	DA	36	06	E5	3BE	...	...
0608	CD	5F	01	3D	16	06	CD	77	2C9	...	...
0610	04	44	4D	E1	71	28	70	C9	343	...	...
0618	C3	36	06	CD	5F	01	3B	28	28A	...	...
0620	06	F1	C3	61	02	CD	5F	01	34A	...	...
0628	0D	2D	06	F1	C3	52	02	C9	311	...	...
0630	CD	1E	01	FE	0D	C3	D5	11	3A5	...	...
0638	AF	01	97	CD	C3	06	D1	1A	3C8	...	...
0640	F5	97	12	2A	0B	10	E5	7E	346	...	...
0648	23	B6	D1	CA	BB	01	7E	B7	465	#	...
0650	FA	FD	03	CD	40	07	1B	F1	41A	...	...
0658	12	3E	3F	CD	E7	07	97	CD	3AE	>	?
0660	C3	06	C3	BB	01	D5	11	B5	3E3	...	...
0668	01	C3	3A	06	CD	E7	07	ED	3AC	...	...
0670	JB	4E	11	CD	09	01	FE	08	297	!	...
0678	28	17	FE	09	28	06	FE	03	27C	!	...
0680	CA	BB	01	12	13	CD	E7	07	366	...	...
0688	FE	0D	C8	78	CD	61	09	20	3A5	...	...

ADDR	00	01	02	03	04	05	06	07	OKS	01234567
	08	09	0A	0B	0C	0D	0E	0F		89ABCDEF
0690	E2	7B	CD	68	09	28	DC	1B	3BA	.L.H.C..
0698	3E	08	18	E9	7C	B7	FA	9D	411	>... \...
06A0	01	11	52	11	E5	2A	1F	10	1B3	.R.*..
06A8	2B	CD	18	01	E1	D8	1A	95	379	+.....
06B0	47	18	1A	9C	38	04	1B	B0	217	G...8...
06B8	C9	18	18	1A	7E	0D	20	FA	32E	.....
06C0	18	18	E1	47	1A	18	E8	C8	300	...E...
06C8	CD	E7	07	7E	0D	20	F5	C9	4A4	.....
06D0	CD	5F	01	22	E2	06	3E	22	297	... \...
06D8	CD	C3	06	7E	0D	E1	CA	52	49E	... \...
06E0	02	23	28	E9	CD	5F	01	27	285	##... \...
06E8	EC	06	3E	27	18	E9	CD	5F	385	>'... \...
06F0	01	5F	FD	06	3E	0D	CD	E7	362	... \...
06F8	07	CD	E7	07	E1	18	E2	C9	486	... \...
0700	06	00	CD	DF	05	F2	0B	07	2BB	.....
0708	06	2D	0D	D5	11	0A	00	D5	205	-.....
0710	0D	C5	CD	C3	05	78	B1	28	3B3	...X..C
0718	07	E3	2D	E5	60	69	18	F2	3CF	...E..C
0720	C1	0D	79	E7	FA	2E	07	3E	368	...Y..E..>
0728	20	CD	E7	07	18	F3	78	B7	415	...X..C
0730	C4	E7	07	5D	7B	FE	0A	D1	463	...IT...
0738	C8	C6	00	CD	E7	07	18	F4	485	..0..G...
0740	1A	6F	18	1A	67	13	0E	04	142	.C..G...
0748	CD	00	07	3E	20	CD	E7	07	2ED	...>...
0750	97	CD	C3	06	C9	CD	18	01	3DC	.....
0758	C8	1A	02	13	03	18	F6	78	280	...X..C
0760	92	20	08	79	93	C8	1B	2B	2CF	...Y...+
0768	1A	77	18	F3	C1	E1	22	18	373	..E... \...
0770	10	7C	B5	28	10	E1	22	15	291	... \...
0778	10	E1	22	17	10	E1	22	19	256	... \...
0780	10	E1	22	18	10	C5	C9	21	2ED	... \...
0788	49	10	CD	E2	05	C1	39	D2	3D9	... \...
0790	65	06	2A	18	10	7C	B5	28	211	E.*... \...
0798	18	2A	1B	10	E5	2A	19	10	1A0	.*... \...
07A0	E5	2A	17	10	E5	2A	15	10	28A	.*... \...
07A8	E5	2A	18	10	E5	C5	C9	31	3D6	.*... \...
07B0	18	11	3E	0C	CD	E7	07	CD	2F6	...>...
07B8	E5	07	CD	E5	07	97	11	EF	48C	.....
07C0	07	CD	C3	06	21	AF	07	22	296	... \...
07C8	1D	10	21	52	11	22	1F	10	102	..IR... \...
07D0	21	94	30	22	4C	11	21	96	21B	..0..L.. \...
07D8	30	22	4E	11	21	D6	30	22	1FA	0..N.. \...
07E0	50	11	C8	B8	01	3E	0D	C5	2F0	P... \...
07E8	F5	CD	06	01	F1	C1	C9	72	4B6	.....R
07F0	6F	62	6F	74	72	6F	6E	20	323	OBOTRON
07F8	59	31	00	31	33	20	42	41	1C2	Z1010 BA
0800	58	49	43	20	33	2E	30	31	1C1	SIC 3.01
0808	0D	4C	49	53	54	00	7B	02	1C6	.LIST.L.
0810	52	55	4E	00	4C	02	4E	45	1D6	RUN.L.ME
0818	57	00	3D	02	42	59	45	00	176	W.=.BYE.
0820	A0	09	45	4E	44	00	6F	09	1F3	..END.O.
0828	43	53	41	56	45	00	D4	09	21F	CSAVE...
0830	43	4C	4F	41	44	00	E7	09	253	CLOAD...
0838	4E	45	58	54	00	39	03	4C	217	NEXT...L
0840	45	54	00	69	04	49	46	00	195	ET.I.IF.
0848	EC	03	47	4F	54	4F	00	6A	292	..GOTO.J
0850	02	47	4F	53	55	42	00	EB	28D	..GOSUB..
0858	02	52	45	54	55	52	4E	00	1E2	..RETURN.
0860	0D	03	52	45	4D	00	E7	03	1DE	..REM...
0868	46	4F	52	00	28	03	49	4E	1A9	FOR..C.IN
0870	50	55	54	00	07	04	50	52	1A6	PUT...PR
0878	49	0E	54	00	05	02	53	54	239	INT...ST
0880	4F	50	06	45	02	43	41	4C	1B7	OP..F.CAL
0888	4C	00	25	0A	4F	55	54	48	1B6	L.%OUTC
0890	48	41	52	00	26	0B	4F	55	1B0	HAR.&.OU

ADDR	00	01	02	03	04	05	06	07	CKS	01234567	
	08	09	0A	0B	0C	0D	0E	0F		89ABCDEF	
0898	54	00	32	0A	4F	24	00	83	186	T.2.0#..	
08A0	0A	49	24	00	90	0A	50	4F	180	.1\$...PO	
08A8	4B	45	00	0B	0A	54	41	42	28C	KE...TAB	
08B0	00	59	0A	42	59	54	45	00	197	.Y.BYTE.	
08B8	E1	0A	57	47	52	44	00	EB	312	..WORD..	
08C0	00	00	64	04	52	4E	44	00	156	..D.RND.	
08C8	00	05	41	42	53	00	AD	05	215	..ABS..	
08D0	53	49	5A	45	00	B6	05	50	246	SIZE...P	
08D8	45	45	4E	00	04	00	49	4E	289	EKK...IN	
08E0	43	40	41	52	00	30	0B	40	1A1	CHAR.0.H	
08E8	45	58	00	3C	0B	49	4E	00	17B	EX.<.IN.	
08F0	69	0A	27	00	0D	00	54	4F	155	I.'...TO	
08F8	50	00	1C	0B	4C	45	4E	00	156	P...LEN.	
0900	21	0B	00	65	05	54	4F	00	139	I...E.TO.	
0908	38	03	00	36	06	53	54	45	163	0...6.STE	
0910	50	00	44	03	00	40	00	3E	121	P.D..I.>	
0918	3D	00	81	04	23	00	87	04	170	=...#....	
0920	3E	00	8D	04	3D	00	9C	04	1AC	>...#....	
0928	3C	3D	00	94	04	3C	00	A2	1EF	<=...<..	
0930	04	00	A6	04	21	00	08	00	CD	1AE	.....!
0938	1E	01	05	19	13	FE	2E	20	275	.....!	
0940	13	23	0E	28	F6	3E	00	1B	26B	..#.(.>..	
0948	BE	23	0F	23	BE	26	FC	23	315	..(.#. .#	
1950	20	D1	16	E3	3E	00	23	BE	30E	#...>.#.	
0958	28	FC	23	7E	23	66	6F	F1	3A6	..#^#FO.	
0960	E9	E5	2A	50	11	BD	E1	C9	400	..#P.....	
0968	E5	2A	4E	11	BD	E1	C9	CD	4A2	..*N.....	
0970	77	04	EB	21	94	30	EB	CD	403	W...J.0..	
0978	13	01	DA	66	06	7C	E7	FA	38C	...F.\..	
0980	66	06	7E	2F	77	46	B0	C2	350	F.^>WF..	
0988	66	06	22	50	11	7D	D6	84	206	F."P.J..	
0990	6F	7C	DE	00	67	22	4E	11	2B1	C\..6"N.	
0998	2B	2B	22	4C	11	C8	BB	01	254	++"L.....	
09A0	FF	C3	BB	01	81	B0	00	CD	42C	.....!	
09A8	1E	01	21	F0	00	E5	06	10	22B	..!.....	
09B0	06	20	23	10	FB	E1	1A	FE	37D	6 #.....	
09B8	22	20	00	13	10	F8	FE	0D	273	.....*	
09C0	20	09	77	23	7C	B7	20	03	221	(.M#)\..	
09C8	13	18	EB	0D	0C	0A	21	00	21A	.....!	
09D0	10	22	F0	00	2A	1F	10	20	18E	..".*..#	
09D8	22	E2	00	0D	0C	01	CD	19	2C4	.....!	
09E0	0A	CD	0C	01	C3	BB	01	31	294	.....!	
09E8	00	00	0D	0C	0A	CD	0F	01	270	.....!	
09F0	21	F0	00	ED	5B	2B	00	01	285	!.....!	
09F8	10	00	ED	B0	ED	53	2B	00	313	.....S+..	
0A00	CD	E5	07	CD	19	00	CD	0F	385	.....!	
0A08	01	C3	BB	01	21	E0	00	22	2A3	.....!	
0A10	1B	00	21	FF	00	22	1D	00	17A	..!.....	
0A18	C9	21	E0	00	11	1B	00	01	1F7	..!.....	
0A20	04	00	ED	B0	C9	CD	77	04	3B2	.....M.	
0A28	D5	01	2E	0A	C5	E9	D1	CD	45A	.....	
0A30	25	01	CD	75	05	E5	CD	5F	37E	%..U.....	
0A38	01	3D	54	0A	CD	77	04	45	229	..=T...W..E	
0A40	3E	D3	32	05	10	E1	7D	32	2E9	>.2...12	
0A48	07	10	3E	C9	32	00	10	70	1E0	..>.2...X	
0A50	CD	06	10	CD	25	01	C3	36	2CF	..>.2...6	
0A58	06	CD	75	05	7C	B5	CC	25	38F	..U.\...%	
0A60	01	2B	3E	20	CD	E7	07	10	25D	..+>.....	
0A68	F3	CD	75	05	E5	3E	DB	32	46A	..U.>.2	
0A70	06	10	E1	7D	32	07	10	3E	1FB	..12...>	
0A78	C9	32	00	10	CD	06	10	26	21C	..2...&	
0A80	00	6F	C9	CD	77	04	D5	EB	440	..O...W..E	
0A88	AF	CD	C3	05	D1	CD	25	01	409	.....%	
0A90	CD	77	04	D5	EB	2A	1F	10	361	..M...*..	
0A98	EB	CD	10	01	DA	66	06	ED	404	.....F..	

ADDR	00	01	02	03	04	05	06	07	CKS	01234567
	08	09	0A	0B	0C	0D	0E	0F		89ABCDEF
0AA0	5B	4E	11	CD	73	06	44	4D	291	IN..S.DM
0AA8	EB	2B	ED	5B	4E	11	D5	CD	45F	..+.IN...
0AB0	55	07	AF	02	D1	23	CD	D8	3A6	U.....#..
0AB8	05	EB	21	00	10	73	23	72	229	..I...S#R
0AC0	D1	CD	25	01	CD	75	05	6E	379	..%...U.N
0AC8	26	00	C9	CD	77	04	E5	CD	3E9	%...W...
0AD0	5F	01	2C	DC	0A	CD	77	04	2BA	.....M.
0AD8	7D	E1	77	CD	25	01	C3	36	3C1	I.W.%...6
0AE0	06	CD	75	05	7D	CD	F9	0A	39A	..U.I...
0AE8	CD	25	01	CD	75	05	7C	CD	383	..%..U.\%
0AF0	F9	0A	7D	CD	F9	0A	CD	25	442	..I.....%
0AF8	01	F5	7F	0F	0F	0F	CD	02	201	.....
0B00	0B	F1	E6	0F	C6	90	27	CE	43C	.....
0B08	40	27	C3	E7	07	1A	13	6F	2B4	0'.....0
0B10	26	00	CD	5F	01	27	17	0B	19C	%.._...'..
0B18	C9	C3	36	06	2A	1F	10	23	244	..6*...#
0B20	C9	2A	06	10	2B	C9	CD	77	33B	..*...+...M
0B28	04	7D	CD	E7	07	CD	25	01	32F	.I.....%
0B30	CD	09	01	FE	03	CA	BB	01	35E	.....
0B38	26	00	6F	C9	C5	21	00	00	244	%..0...I..
0B40	CD	5F	01	23	60	0B	1A	FE	2D8	.._..(e...
0B48	0D	CA	36	06	CD	67	0B	29	27B	..6...G.)
0B50	23	23	23	05	00	4F	09	13	0EC	)))...0..
0B58	CD	5F	01	29	5E	0B	18	05	1DC	.._..)^...^
0B60	18	E4	C3	36	06	C1	C9	FE	483	..7..6...^
0B68	30	FA	36	06	FE	39	FA	7E	415	0.G.6...0
0B70	0B	CA	7E	0B	FE	41	FA	36	3CD	..^...A.6
0B78	06	FE	47	F2	36	06	D6	30	37F	..G.6...0
0B80	FE	0A	F8	D5	07	C9	CD	93	506	.....
0B88	0B	FE	03	23	0F	FE	05	C0	306	...(. ....
0B90	C3	BB	01	3E	03	D3	03	DB	376	...>.....
0B98	02	E6	0F	C9	D5	11	FF	FF	4A4	.....
0BA0	1B	7A	BB	20	FB	D1	C9	52	44F	..Z...R
0BA8	49	42	55	54	45	20	22	53	20E	IBUTE "S

ANLAGE 13: MC-BEISPIELPROGRAMME  
 \*\*\*\*\*

1. ZÄHLERMODUL

Mit diesem Programm können über den Tonbandedingang NF-Messungen ausgeführt werden. Startadresse: 3C00H

	MPRT /3				3C00H/3E8FH					
ADDR	00	01	02	03	04	05	06	07	CKS	01234567
	08	09	0A	0B	0C	0D	0E	0F		89ABCDEF
3C00	21	07	3D	01	03	03	ED	B3	20C	!.=.....
3C08	31	ED	3E	CD	BA	3C	CD	C6	4B2	!.>...<..
3C10	3C	21	38	3D	11	06	EE	01	1D8	<!8=.....
3C18	15	00	ED	B0	E7	01	FE	0D	3A5	..:.....
3C20	CC	A8	3C	CD	BA	3C	CD	C6	506	..<...<..
3C28	3C	21	26	3D	11	08	EE	01	248	<!&=.....
3C30	12	00	ED	B0	11	18	32	21	228	..:.....2!
3C38	ED	3E	36	35	21	00	00	44	1F5	..>60!...D
3C40	7B	B2	28	13	DB	02	4F	00	314	[.(...0.
3C48	41	0B	77	CA	53	3C	23	1B	31A	A..W..S<#.
3C50	C3	45	3C	1B	00	13	E9	2E	286	..e<.....+
3C58	DD	21	92	EE	11	10	27	CD	398	..!.....!
3C60	7D	3C	11	E8	03	CD	7D	3C	338	!<...!<
3C68	11	64	00	CD	7D	3C	11	0A	216	..D...J<..
3C70	00	CD	7D	3C	11	01	00	CD	265	..J<...!.
3C78	7D	3C	03	34	3C	AF	06	FF	3A0	!<.4<...!
3C80	04	ED	52	30	FB	19	78	C6	305	..R0...X:
3C88	30	FE	30	28	09	02	ED	3E	2EC	0..0(.2.>
3C90	DD	77	00	DD	23	09	E5	21	423	..W...#...!
3C98	ED	3E	BE	E1	20	F2	3E	20	48A	..>...>
3CA0	18	EE	36	FF	19	10	FB	09	428	..6.....
3CA8	21	4D	3D	11	00	EE	01	40	1EB	!M=.....e
3CB0	01	ED	B0	E7	01	FE	0D	20	3B1	..:.....
3CB8	FA	C9	21	00	EC	06	20	23	349	..!...6 #
3CC0	CB	64	CA	BD	3C	C9	21	00	45C	..D...<!..
3CC8	EC	11	01	00	06	20	CD	A2	298	..:.....
3CD0	3C	21	30	ED	06	20	CD	A2	361	<!... ..
3CD8	3C	21	00	ED	06	20	CD	A2	35F	<!... ..
3CE0	3C	11	20	00	06	18	21	00	12C	<... ..!
3CE8	EC	CD	A2	3C	21	9F	EC	06	449	...<!...!
3CF0	18	CD	A2	3C	21	00	3D	11	23C	...<!...=.
3CF8	02	ED	01	1C	00	ED	B0	E9	372	..:.....
3D00	1B	7B	B2	C2	00	3D	C9	CF	3DF	..[...=..
3D08	FF	07	5A	20	31	30	31	30	245	..Z 1013
3D10	20	2D	20	53	4F	46	54	20	1C9	- SOFT
3D18	2D	20	5A	41	45	48	4C	45	206	- ZAEHLE
3D20	52	4D	4F	44	55	4C	46	52	26B	RMODULFR
3D28	45	51	55	45	4E	5A	3A	20	232	EQUENZ:
3D30	20	20	20	20	20	20	48	7A	182	.. .. HZ
3D38	42	65	64	69	65	6E	75	6E	32A	BEDIENUN
3D40	67	73	61	6E	6C	63	69	74	357	GSANLEIT
3D48	75	6E	67	20	3F	FF	20	20	2E3	UNG ?.
3D50	46	72	65	71	75	65	6E	7A	350	FREQUENZ
3D58	6D	65	73	73	75	6E	67	20	322	MESSUNG
3D60	61	6D	20	54	42	2D	45	69	25F	AM TB-EI
3D68	6E	67	2E	20	FF	FF	20	20	361	NG. ..
3D70	20	20	55	65	20	20	20	6D	1C7	.. UE .. M
3D78	69	6E	69	6D	61	6C	20	20	2BC	INIMAL
3D80	20	20	31	30	30	20	6D	56	1B4	.. 100 MV
3D88	20	20	20	20	FF	FF	20	20	2BE	.. ..
3D90	20	20	55	65	20	20	20	6D	1C7	.. UE .. M
3D98	61	78	69	6D	61	6C	20	20	2BC	AXIMAL
3DA0	20	20	20	20	35	20	20	56	14B	.. 5 V
3DA8	20	20	20	20	FF	FF	20	20	2BE	.. ..

```

ADDR 00 01 02 03 04 05 06 07 CKS 01234567
      08 09 0A 0B 0C 0D 0E 0F 89ABCDEF
=====
3DB0 20 20 66 65 20 20 20 6D 1D8 FE M
3DB8 61 78 69 6D 61 6C 20 20 2BC AXIMAL
3DC0 20 20 20 31 32 20 6B 48 196 12 KH
3DC8 7A 20 20 20 FF FF 20 20 318 Z ..
3DD0 20 20 20 20 20 20 20 20 180
3DD8 20 20 20 20 20 20 20 20 180
3DE0 20 20 20 20 20 20 20 20 180
3DE8 20 20 20 20 FF FF 20 20 2BE
3DF0 20 43 50 55 2D 54 61 6B 255 CPU-TAK
3DF8 74 20 20 20 5A 4B 3D 28 1DE T ZK=(
3E00 33 43 33 35 48 2F 33 36 1BE 3C35H/36
3E08 48 29 20 20 FF FF 20 20 2EF H) ..
3E10 20 20 20 31 20 4D 48 7A 1C0 1 MHZ
3E18 20 20 20 20 20 20 20 20 180
3E20 31 39 30 43 48 20 20 20 176 190CH
3E28 20 20 20 20 FF FF 20 20 2BE
3E30 20 20 20 32 20 4D 48 7A 1C1 2 MHZ
3E38 20 20 20 20 20 20 20 20 180
3E40 33 32 31 33 48 20 20 20 176 3218H
3E48 20 20 20 20 FF FF 20 20 2BE
3E50 20 56 6F 72 7B 61 65 68 2FF VORZAEH
3E58 6C 65 72 20 56 5A 3D 28 278 LER YZ=(
3E60 33 43 33 44 48 2F 33 45 1DC 3C3DH/3E
3E68 48 29 20 20 FF FF 20 62 331 H) .. B
3E70 65 69 20 54 41 4B 54 3D 25F EI TAKT=
3E78 31 20 4D 48 7A 3A 20 66 220 1 MHZ: F
3E80 65 20 6D 61 78 20 36 20 241 E MAX 6
3E88 6B 48 7A 20 FF FF FF FF 549 KMZ ....

```

## 2. MUSIKMODUL

Mit diesem Programm können Sie Melodien über den Tonbandausgang abspielen, die Sie vorher programmiert haben. Drehen Sie also den Lautstärkeregelner Ihres angeschlossenen Magnetbandgerätes etwas auf und stellen Sie "Aufnahme" ein.

Das Programm besteht aus drei Teilen; dem eigentlichen Programm ab Adresse 100H und einer Hilfstabelle ab Adresse 170H.

Die Melodie wird im Speicher ab Adresse 190H abgelegt und nach folgender Vorschrift gebildet:

1. Ein Ton erfordert die Eingabe von Hexadezimalziffern:

Tonlänge - Tonhöhe - Pausenlänge - Pausenzeichen (FFH)

2. Tonlänge

als HEXA-Zahl	60	30	18	0B	06
Länge der Note	1	1/2	1/4	1/8	1/16

Die Bildung der Pausenlänge ist analog.

3. Tonhöhe

	02	06		0C	10	14		
	<u>CIS</u>	<u>DIS</u>		<u>FIS</u>	<u>GIS</u>	<u>AIS</u>		
	C	D	E	F	G	A	H	C
	<u>00</u>	<u>04</u>	<u>08</u>	<u>0A</u>	<u>0E</u>	<u>12</u>	<u>16</u>	<u>18</u>

4. Melodieende durch ein Nullbyte (00H)

Als Beispiel sei hier das Lied "Kein schöner Land ..." angegeben. Nach Eingabe aller drei Teile kann das Programm auf der Adresse 100H gestartet werden.

Natürlich können Sie auch selbst Melodien programmieren, wenn Sie nach der obigen Bildungsvorschrift verfahren und Ihre Melodie ab 190H mit dem M-Kommando einspeichern.

MC-Listing:

```

MPRT /3          0100H/025FH

ADDR 00 01 02 03 04 05 06 07 CKS 01234567
      08 09 0A 0B 0C 0D 0E 0F      89ABCDEF
=====
0100 AF 32 6C 01 18 04 3E 01 1A9 .2L...>.
0108 18 F7 21 90 01 7E B7 CA 308 ..!..^..

```

ADDR	00	01	02	03	04	05	06	07	OKS	01234567
	08	09	0A	0B	0C	0D	0E	0F		89ABCDEF
0110	38	00	4E	23	E5	7E	5E	16	280	8.N#.^^.
0118	00	FE	FF	28	07	CD	3F	01	339	...(.?.
0120	E1	23	18	E9	06	80	10	FE	399	..#.....
0128	06	80	10	FE	3A	6C	01	B7	2F2	.....:L..
0130	28	08	06	80	10	FE	06	80	24A	(.....
0138	10	FE	0D	20	E7	18	E1	21	38C	... ..!
0140	70	01	19	56	23	7E	81	4F	251	P..V#^..0
0148	CB	FF	D8	02	42	10	FE	3A	429	.....B...:
0150	6C	01	B7	28	03	42	10	FE	29F	L..(.B..
0158	CB	FF	D8	02	42	10	FE	3A	429	.....B...:
0160	6C	01	B7	28	03	42	10	FE	29F	L..(.B..
0168	0D	20	0D	C9	00	0A	00	00	1DD	.....
0170	A0	00	98	07	90	0F	87	17	27C	.....
0178	80	1F	78	27	70	2F	6A	34	27B	..X'P/J4
0180	65	3A	60	3F	5B	43	56	49	27B	E:e?ICVI
0188	4F	50	44	00	00	00	00	00	0E3	OPD.....
0190	30	00	18	FF	30	00	18	FF	28E	0...0...
0198	30	00	18	FF	30	0A	18	FF	2C8	0...e...
01A0	60	12	18	FF	30	0E	0B	FF	2D1	0...0...
01A8	30	0A	0B	FF	60	0E	B0	FF	361	0...e...
01B0	30	00	18	FF	30	00	18	FF	28E	0...0...
01B8	30	00	18	FF	30	0A	18	FF	2C8	0...e...
01C0	60	12	18	FF	30	0E	0B	FF	2D1	0...0...
01C8	30	0A	0B	FF	60	0E	B0	FF	361	0...e...
01D0	30	12	0B	FF	30	0A	0B	FF	290	0...0...
01D8	30	0E	0B	FF	30	12	0B	FF	294	0...0...
01E0	30	18	0B	FF	30	14	0B	FF	2A0	0...0...
01E8	30	12	0B	FF	30	0E	0B	FF	294	0...0...
01F0	30	0A	0B	FF	30	0E	0B	FF	28C	0...0...
01F8	30	14	0B	FF	30	12	0B	FF	29A	0...0...
0200	30	0E	0B	FF	30	0A	0B	FF	28C	0...0...
0208	30	0E	0B	FF	60	12	0B	FF	369	0...e...
0210	30	12	0B	FF	30	0A	0B	FF	290	0...0...
0218	30	0E	0B	FF	30	12	0B	FF	294	0...0...
0220	30	18	0B	FF	30	14	0B	FF	2A0	0...0...
0228	30	12	0B	FF	30	0E	0B	FF	294	0...0...
0230	30	0A	0B	FF	30	0E	0B	FF	28C	0...0...
0238	30	14	0B	FF	30	12	0B	FF	29A	0...0...
0240	30	0E	0B	FF	30	0A	0B	FF	28C	0...0...
0248	30	08	0B	FF	60	0A	B0	FF	35B	0...e...
0250	00	00	00	00	00	00	30	00	030	.....0.
0258	00	00	00	00	00	00	00	00	000	.....

### 3. ORGEL

Eine andere Möglichkeit des Musikmachens mit dem Z 013 bietet dieses kleine Pogramm. Wenn Sie es ab Adresse 300H eingeben, das Tonbandgerät auf "Aufnahme" stellen und die Lautstärke etwas aufdrehen, können Sie die untere Reihe der Tastatur als kleine Orgeltastatur benutzen. Der Inhalt der Speicherzelle mit der Adresse 31FH bestimmt die Tonlänge eines Zyklus'. Die Tonhöhe der einzelnen Tasten wird in der Tabelle ab Adresse 333H gespeichert. Sie können mit dem M-Kommando ab Adresse 333H auch eine andere Tonleiter eingeben.



Zum Beispiel:

```

      MPRT /3      0300H/034FH
ADDR 00 01 02 03 04 05 06 07 CKS 01234567
      08 09 0A 0B 0C 0D 0E 0F      89ABCDEF
-----
0300 06 08 11 3B 03 21 33 03 0B4 ....:..!S.
0308 1A D3 08 DB 02 E6 0F FE 3C5 .:.....:
0310 07 28 0B FE 05 CA 38 00 23F .(.:...:8.
0318 23 13 10 EC 18 E2 0E 50 28A #.....:P
0320 0B FF D3 02 46 10 FE 0B 4BE .:...F...
0328 BF D3 02 46 10 FE 0D 20 315 ...F....
0330 EF 18 CD 80 71 65 5F 55 3DE .:...QE_U
0338 4B 43 3E 00 01 02 03 04 0D6 KC>.....
0340 05 06 07 30 FA 19 22 96 20D ...0...:
0348 07 21 F9 0B 3E 01 B8 3E 261 .!...>..>

```

#### 4. SIRENE

Wenn Sie das nachfolgende Programm eingeben und Ihr Tonbandgerät wie oben einrichten, so erhalten Sie nach dem Starten als Ergebnis einen auf- und abschwellenden Ton. Dieser Sirenenton kann auch aufgezeichnet und für das obige Programm "ZÄHLERMODUL" als Eingangssignal verwendet werden. Durch Veränderung der Speicherzellen auf den Adressen mit neuen Inhalten ist der Sirenenton (bei 2 MHz) in weiten Grenzen variierbar:

```

381H      30H...20H...10H      60H
383H      60H...40H...11H      E0H
385H      01H...10H...04H      10H
3ABH      30H...20H...10H      60H

```

```

      MPRT /3      0380H/03CFH
ADDR 00 01 02 03 04 05 06 07 CKS 01234567
      08 09 0A 0B 0C 0D 0E 0F      89ABCDEF
-----
0380 2E 30 16 60 1E 01 3E 03 134 .0.e..>.
0388 D3 08 DB 02 E6 0F FE 05 3B0 .:.....:
0390 CA 38 00 4B EE 80 D3 02 390 .8.K....
0398 42 10 FE EE 80 D3 02 42 3D5 B.....B
03A0 10 FE 0D 20 EF 15 1C 2D 288 .:.....-
03A8 20 E9 2E 30 4B EE 80 D3 3F3 ..0K...
03B0 02 42 10 FE EE 80 D3 02 395 .B.....
03B8 42 10 FE 0D 20 EF 14 1D 29D B.....
03C0 2D 20 E9 13 BB C3 C3 01 390 -.....:
03C8 DD 36 08 00 CD D5 04 16 2D7 .6.....

```

#### 5. OHNE FLEISS - KEIN PREIS

Mit dem folgenden Programm können Sie schon ein kleines Computerspiel durchführen. Das Programm wird ab Adresse 100H bis Adresse 353H eingegeben und auf Adresse 100H gestartet. Mit "->" wird die jeweilige Zal nach rechts, mit "<-" nach links, mit "U" nach oben und mit "\_" (Leertaste) nach unten bewegt.

ADDR	00	01	02	03	04	05	06	07	CKS	01234567
	08	09	0A	0B	0C	0D	0E	0F		89ABCDEF
0100	E7	02	0C	0D	0D	20	20	20	16F	.....
0108	4F	48	4E	45	20	46	4C	45	221	DMNE FLE
0110	49	53	53	20	4B	45	49	4E	248	ISS-KEIN
0118	20	50	52	45	49	53	50	2A	26D	PREIS.*
0120	2E	00	36	20	21	08	ED	06	19D	+..6 !..
0128	0F	36	7F	23	10	FB	21	36	2C9	..6.#..!6
0130	ED	11	20	00	06	0A	36	7F	263	.. ..6.
0138	19	10	FE	21	55	EE	06	0E	29C	..!U..
0140	36	7F	2B	10	FB	21	28	EE	3A2	6.+..!(.
0148	06	0A	7F	36	7F	ED	52	10	343	..6..R.
0150	FA	21	49	ED	22	2E	00	3E	2DC	!I."+.>
0158	16	0E	04	06	04	F5	E7	02	210	.....
0160	A0	F1	E7	06	D6	01	27	10	38C	.....'
0168	F4	0D	28	12	2A	20	00	36	1C6	..(.#+.6
0170	20	11	34	00	19	36	20	22	0F6	..4..6 "
0178	2B	00	06	04	10	DF	2A	2B	181	+.....*+
0180	00	36	20	21	4A	ED	22	2B	1FB	..6 !U."+
0188	00	36	20	23	36	20	21	E0	1D0	..6 #6 !.
0190	EE	22	2E	00	21	A6	01	7E	281	.."+.!..^
0198	E7	00	23	7E	9A	20	F0	2A	3E4	..#..*.
01A0	2B	00	36	20	18	54	53	3D	17D	+..6 .TS=
01A8	53	54	41	52	54	2C	20	4E	228	START, N
01B0	3D	5A	41	45	48	4C	45	52	248	=ZAEHLER
01B8	20	4E	55	4C	4C	0D	43	54	1FF	NULL.CT
01C0	52	4C	2D	43	3D	41	42	42	210	RL-C=ABB
01C8	52	55	43	43	0D	20	20	20	19F	RUCH.
01D0	20	20	9D	0D	20	20	20	20	16A	..
01D8	20	A1	0D	20	20	20	20	20	150	..
01E0	55	0D	20	3C	2D	20	20	2D	158	U. <- -
01E8	20	20	2D	3E	0D	20	20	20	118	->.
01F0	20	20	A1	0D	20	20	20	20	16E	..
01F8	20	9A	7F	32	54	03	32	55	279	..2T.2U
0200	03	7F	32	56	03	32	57	03	1C9	..2V.2M.
0208	CD	24	03	18	03	CD	0D	03	1EC	..#.....
0210	E7	01	7E	53	0A	00	01	7E	402	..8.....
0218	55	CA	A4	02	7E	08	CA	37	3DC	..N.....
0220	02	7E	4E	CA	01	02	7E	09	322	..N.....
0228	CA	06	02	7E	20	CA	7F	02	3FB	.....
0230	7E	03	CA	38	00	18	D9	3A	32E	..8.....
0238	54	03	7E	03	CA	10	02	3C	270	T.....<
0240	32	54	03	3D	CD	E8	02	3A	2B7	2T.0.....
0248	55	03	CD	7E	02	21	44	03	28D	U.....!D.
0250	CD	04	03	01	03	00	09	06	0E7	.....
0258	03	22	58	03	D5	11	5B	03	1C4	..X...L.
0260	7E	12	23	13	10	FA	D1	21	2C2	^.#...!
0268	5B	03	06	03	7E	12	23	13	12D	L...^.#.
0270	10	FA	2A	58	03	06	03	36	1CE	..*X...6
0278	20	20	10	FB	C3	0D	02	3A	25A	#.....
0280	55	03	7E	03	CA	10	02	3D	257	U.....=
0288	32	55	03	3C	CD	F0	02	3A	2BF	2U.<.....
0290	54	03	CD	7E	02	21	4C	03	294	T.....!L.
0298	CD	04	03	01	40	00	A7	ED	2A9	.....0....
02A0	42	C3	57	02	3A	55	03	7E	2EE	B.W.:U..
02A8	03	CA	10	02	3C	32	55	03	1A5	.....<2U.
02B0	3D	CD	F0	02	3A	54	03	CD	35A	=.....T..
02B8	7E	02	21	4C	03	CD	04	03	244	..!L.....
02C0	01	40	00	C3	56	02	3A	54	1EA	..0...V.:T
02C8	03	F6	00	CA	10	02	3D	32	244	.....=2
02D0	54	03	3C	CD	E8	02	3A	55	2D9	T.<.....U
02D8	03	CD	7E	02	21	44	03	CD	305	.....!D..
02E0	54	03	01	03	00	C3	9E	02	18E	.....
02E8	47	CB	27	00	06	00	4F	C9	2D7	G.'...0.
02F0	47	B7	28	06	0E	40	7F	81	2AA	G.(...0..

Byte 8 = 20?

ADDR	00	01	02	03	04	05	06	07	CKS	01234567
	08	09	0A	0B	0C	0D	0E	0F		89ABCDEF
02F8	10	FD	06	00	4F	C9	0B	27	31D	.....0..'
0300	16	00	5F	C9	19	5E	23	56	22E	.....^#V
0308	EB	09	E5	D1	C9	A7	3A	56	4AA	.....:Y
0310	03	06	01	27	32	56	03	3A	1B6	.....'2V.:
0318	57	03	CE	00	27	32	57	03	1DB	W.....'2M.
0320	CD	24	00	C9	2A	2B	00	36	248	.\$...*+.6
0328	20	21	8A	EE	22	2B	00	E7	2ED	!..."+.
0330	02	5A	55	47	2D	4E	52	3A	1FF	.ZUG-NR:
0338	A0	2A	56	03	E7	07	2A	2B	266	.*U...*+
0340	00	36	20	C9	49	ED	09	ED	3CB	*6 .1...
0348	C9	ED	09	EE	49	ED	4C	ED	51C	.....1.L.
0350	4F	ED	52	ED	00	00	00	01	27C	O.R.....
0358	00	00	00	00	00	00	00	000		.....

ANLAGE 14: BASIC-BEISPIELPROGRAMME

\*\*\*\*\*

Die hier ANGEGEBENEN PROGRAMME IN DER PROGRAMMIERSPRACHE BASIC  
ERFORDERN DIE Z 1013-VARIANTE MIT 16K RAM UND DAS  
VORHANDENSEIN DES "3K-BASIC VON RER". EINE ERLAEUTERUNG DER  
PROGRAMME ERFOLGTE NUR DORT, WO ES FUER ERFORDERLICH GEHALTEN  
WURDE. ANSONSTEN REICHT DIE ENTHALTENE BEDIENERFUEHRUNG FUER  
DAS VERSTAENDNIS DER PROGRAMME AUS.

1. BASIC-PROGRAMM ZUM SPEICHERN VON ADRESSEN UND  
TELEFONNUMMERN

\*\*\*\*\*

MIT DISEM BASIC-PROGRAMM IST ES MOEGlich, EIN  
ADRESSVERZEICHNIS AUFZUBAUEN, ANZUZEIGEN UND ZU KORRIGIEREN.  
MAN KANN ABER AUCH NACH EINEM BESTIMMTEN NAMEN SUCHEN, ALLE  
ADRESSEN NACH DEN ANFANGSBUCHSTABEN SORTIEREN UND EIN  
VERZEICHNIS AUF DEM BILDSCHIRM AUSGEBEN LASSEN, IN DM NUR  
TELEFONNUMMERN UND NAME ERSCHEINEN, WENN VOR PROGRAMMSTART DIE  
RAM-GRENZE MIT DER ANWEISUNG

END HEX(3FFF)-64

IN BASIC ERWEITERT WIRD, SIND MAXIMAL 80 ADRESSEN SPEICHERBAR.  
BEI HOEHEREN FORDERUNGEN MUESSEN DIE DATAN AUF  
MAGNETBANDKASSETTE ABGESPEICHERT WERDWN ODER ES IST EIN  
ANDERES SATZFORMAT ZU WAEHLEN (IM PROGRAMM IST DIE SATZLAENGE  
AUF 100 BYTES FESGELEGT), DER DATEI-ANFANG WURDE IN ZELE 40  
MIT E=8600 FESTGELEGT. VOR PROGRAMMSTART MIT RUN IST MIT PRINT  
TOP,SIZE ZU KONTROLLIEREN, DASS DER WERT FUER TOP KLEINER ALS  
8600 IST, ANSONSTEN MUESSTE DER ANFANGSWERT FUER E ERHOEHT  
WERDEN.

```
10 REM ADRESSEN- UND TELEFONNUMMERNVERZEICHNIS
20 OUTCHAR 12
30 PRINT: PRINT"ADRESSEN- UND TELEFONNUMMERN-"
35 PRINT" VERZEICHNIS"
40 PRINT: V=100: E=8600
50 PRINT"DATEI NEU ? (J/ENT):";
60 W=INCHAR: OUTCHAR W: PRINT: PRINT
70 IF W=13 GOTO 160
80 IF W#J GOTO 50
90 INPUT"MAX: ANZAHL DATENSATZTE"Q
100 IF Q<1 GOTO 90
110 U=E+(Q*V)
115 IF (U-E)>(SIZE-(E-TOP)) GOTO 90
120 FOR I=E TO U
130 POKE I,82
140 NEXT I
150 POKE E,'*'
160 FOR K=E TO U STEP V
170 IF PEEK(K)='*' GOTO 190
180 NEXT K
190 A=(K-E)/V
200 PRINT"VON ",#4,Q," DATENSATZTEN"
210 PRINT"SIND",#4,A," ERFASST"
230 PRINT: PRINT"AUSWAHL DURCH KENNZIFFER"
250 PRINT: PRINT"AUFBAU.....0"
260 PRINT: PRINT"ANZEIGEN.....1"
270 PRINT: PRINT"SUCHEN.....2"
280 PRINT: PRINT" SORTIEREN.....3"
```

```

290 PRINT; PRINT"ANZEIGEN.TEL.-NR..4"
300 PRINT; PRINT"ÄNDERM.....5"
310 PRINT; PRINT"STATUS.....6"
312 PRINT; PRINT"DATEN RETTEN.....7"
315 PRINT; PRINT"DATEN EINLESEN.....8"
318 PRINT
320 INPUT"EINGABE KENNZIFFER"W
325 IF W<0 GOTO 320
330 IF W>0 GOTO 320
340 GOTO (W*300+400)
400 REM DATEIAUFBAU
410 IF K=U PRINT"DATEI VOLL !"; PRINT; GOTO 190
420 X=K
430 GOSUB 8000
435 K=K+V
440 POKE K,"*"; GOTO 190
700 REM ANZEIGEN
705 IF K=E PRINT"DATEI LEER !"; PRINT; GOTO 190
710 GOSUB 5000
720 GOSUB 5200
730 GOSUB 7000
740 IF Y=B GOTO 1890
750 X=X+V
760 Z=Z+1; Y=Y+1
770 IF Z=4 GOSUB 1850
780 IF X>=K GOTO 1890
790 GOTO 730
1000 REM SUCHEN
1020 FOR S=U+10 TO U+30
1030 POKE S,32
1040 NEXT S
1050 PRINT"NAME:";
1060 G=20; I=U+10
1070 GOSUB 10000
1080 FOR J=E TO K STEP V
1090 M=0
1100 FOR I=0 TO 19
1105 IF PEEK(J+I)=32 GOTO 1130
1110 IF PEEK(U+10+I)=PEEK(J+I) GOTO 1170
1120 NEXT I
1130 IF M=1 GOTO 1200
1140 NEXT J
1150 PRINT"NICHT GEFUNDEN"; PRINT; GOTO 190
1170 M=M+1; GOTO 1120
1200 PRINT"GEFUNDEN"
1210 X=J
1215 P=(J-E)/V+1
1220 GOSUB 7000
1240 PRINT; GOTO 190
1300 REM SORTIEREN
1350 FOR J=E TO K-(2*V) STEP V
1360 FOR I=J+V TO K-V STEP V
1370 IF PEEK(J) > PEEK(I) GOTO 1450
1380 NEXT I
1390 NEXT J
1400 GOTO 190
1450 FOR S=0 TO V-1
1460 F=PEEK(J+S); POKE(J+S),PEEK(I+S); POKE(I+S),F
1470 NEXT S
1480 GOTO 1380
1600 REM ANZEIGEN TELEFON-NR.
1605 B=A
1610 GOSUB 5000
1620 PRINT"TELEFON-NR. NAME"
1630 FOR J=1 TO 32
1640 OUTCHAR 42
1650 NEXT J
1660 PRINT
1670 FOR J=X+84 TO X+94

```

```

1680 OUTCHAR (PEEK(J))
1690 NEXT J
1700 OUTCHAR 32
1710 E=20; I=X
1720 GOSUB 10300
1730 X=X+Y
1740 Z=Z+1
1750 IF Z=25 GOSUB 1850
1760 IF X>=K GOSUB 1890
1770 GOTO 1670
1850 TAB(20)
1855 PRINT">ENTER<";
1860 W=INCHAR; OUTCHAR W
1865 IF W#13 GOTO 1860
1870 Z=0; RETURN
1890 TAB(15); PRINT"ENDE";; GOSUB 1855
1895 GOTO 190
1900 REM AENDERN
1920 GOSUB 5000
1930 GOSUB 8000
1940 GOTO 190
2200 REM STATUS
2210 PRINT"DATEISTATUS"; PRINT
2220 FOR I=E TO U STEP V
2230 WORD(I); PRINT" ";
2240 OUTCHAR (PEEK(I)); OUTCHAR (PEEK(I+1))
2250 TAB(1)
2260 NEXT I
2270 PRINT
2280 GOTO 190
2500 REM DATEN RETTEN
2510 FOR J=HEX(F0) TO HEX(FF)
2520 POKE J,32
2530 NEXT J
2535 PRINT"FILENAME:";
2540 I=HEX(F0); G=16
2550 GOSUB 10000
2560 POKE HEX(E0),E
2570 POKE HEX(E1),E/256
2580 POKE HEX(E2),K
2590 POKE HEX(E3),K/256
2600 CALL HEX(A0C)
2610 CALL HEX(10C)
2620 CALL HEX(A19)
2630 CALL HEX(10C)
2640 GOTO 200
2800 REM DATEN EINLESEN
2810 CALL HEX(A0C)
2820 CALL HEX(10C)
2830 FOR I=HEX(F0) TO HEX(FF)
2840 OUTCHAR (PEEK(I))
2850 NEXT I
2860 CALL HEX(A19)
2870 CALL HEX(10F)
2880 PRINT; GOTO 160
5000 REM ABFRAGE VON
5010 PRINT; Z=0
5020 INPUT"A POS."P; Y=P-1
5025 IF Y=0 GOTO 5020
5030 X=E+(Y*V)
5040 IF X>=K GOTO 5020
5050 RETURN
5200 REM ABFRAGE BIS
5220 INPUT"BIS POS."W; B=W-1
5230 IF B<A-1 GOTO 5220
5240 IF B<Y GOTO 5220
5250 RETURN
7000 REM AUSGABE EINES DATENSATZES
7010 PRINT

```

```

7020 PRINT"LFD.NR.",#4,P," ";
7040 G=20; I=X
7050 GOSUB 10300
7060 TAB (12)
7070 I=X+20
7080 GOSUB 10300
7100 PRINT"PLZ: ";
7110 FOR J=X+(= TO X+(□
7120 OUTCHAR (PEEK(J))
7130 NEXT J
7150 TAB(3)
7160 G=20; I=X+40
7170 GOSUB 10300
7180 TAB (12)
7190 I=X+60
7200 GOSUB 10300
7210 PRINT"TELEFON-NR. ";
7220 G=16; I=X+84
7230 GOSUB 10300
7240 PRINT; F=P-1; RETURN
8000 REM EINGABE EINER POSITION
8010 PRINT"NAME      ";
8020 G=20; I=X
8030 GOSUB 10000
8040 PRINT"VORNAME  ";
8050 I=X+20
8060 GOSUB 10000
8070 PRINT"PLZ      ";
8080 G=4; I=X+80
8090 GOSUB 10000
8100 PRINT"Wohnort   ";
8110 G=20; I=X+40
8120 GOSUB 10000
8130 PRINT"STRASSE  ";
8140 I=X+60
8150 GOSUB 10000
8160 PRINT"TELEFON  ";
8170 G=11; I=X+84
8180 GOSUB 10000
8190 RETURN
10000 REM EINGABE EINES DATENSATZES
10010 Z=1; H=I+G
10020 IF PEEK(I)=32 GOTO 10100
10030 IF PEEK(I)='*' GOTO 10100
10040 OUTCHAR (PEEK(I)); I=I+1
10045 IF I=H GOTO 10100
10050 IF PEEK(I)#32 GOTO 10040
10100 W=INCHAR
10110 IF W=8 I=I-1; GOTO 10200
10120 IF W=9 I=I+1; GOTO 10250
10130 IF W=13 OUTCHAR W; RETURN
10140 POKE I,W
10150 I=I+1
10160 OUTCHAR W
10170 IF I#W GOTO 10100
10180 PRINT; RETURN
10200 IF I<2 I=I+1; GOTO 10100
10210 GOTO 10160
10250 IF I>H I=I-1; GOTO 10100
10260 GOTO 10160
10300 REM AUSGABE EINES DATENSATZES
10310 FOR J=I TO I+G-1
10320 OUTCHAR (PEEK(J))
10330 NEXT J
10340 RETURN

```

## 2. BASIC-PROGRAMM "BEGRIFFE RATEN"

\*\*\*\*\*

Mit diesem BASIC-Programm können Begriffe, Sprichwörter oder Sätze abgespeichert werden. Die maximale Satzlänge sollte ein Vielfaches von 32 sein. Die maximale Anzahl der Sätze sollte nicht über 120 liegen. Entsprechend dem Menü kann der Spielmeister die Begriffe aufbauen, zur Kontrolle anzeigen, korrigieren, testen und auf Magnetbandkassette abspeichern. Die Spielidee besteht darin, daß in einer Spielrunde vom Spielmeister Begriff für Begriff abgerufen werden kann. Dabei wird jeder Buchstabe des Begriffes durch einen Strich angezeigt.

Die Mitspieler haben nun die Möglichkeit, den Begriff zu erraten bzw. durch Eingabe eines Buchstabens diesen im Begriff an allen vorkommenden Stellen aufzublenden. Damit wird der Begriff immer vollständiger.

Wurde der Begriff von einem Mitspieler richtig erraten, so kann dieser durch Betätigen der ENTER-Taste zur Anzeige gebracht werden.

```
1  REM BEGRIFFE RATEN
2  REM E = ANFANGSADRESSE DER DATEI
3  REM I,J,S = LAUFINDEX
4  REM V = SATZLAENGE
5  REM Q = MAXIMALE ANZAHL DATENSAETZE
6  REM U = MAXIMALE DATEIGROESSE IN BYTES
7  REM A = AKTUELLE ANZAHL VON DATENSAETZEN
8  REM K = AKTUELLER FUELLSTAND DER DATEI
9  REM L = ANZAHL DER VERSUCHE
10 REM M = MERKZELLE FUER VOLLSTAENDIGKEIT
11 REM W = E/A-ZELLE
12 REM Y = POSITION AB ABSOLUT
13 REM X = ANFANGSADRESSE AUSG#EWAEHLTE POSITION
14 REM H = ENDADRESSE AUSGEWAHLTE POSITION
15 REM B = POSITION BIS ABSOLUT
16 REM Z = ZEILENZAEHLER
20 OUTCHAR 12
22 E=HEX(2000)
25 PRINT; PRINT"ERRATEN VON BEGRIFFEN"; PRINT
30 PRINT"DATEI NEU ? (J/ENT):",
40 W=INCHAR;OUTCHAR W; PRINT; PRINT
50 IF W=13 GOTO 140
60 IF W#J GOTO 30
70 INPUT"MAX. SATZLAENGE"V
80 IF V<1 GOTO 70
90 INPUT"MAX. ANZAHL DATENSAETZE"Q
100 IF Q<1 GOTO 90
105 U=E+(Q*V)
110 FOR I=E TO U
115 POKE I,32
120 NEXT I
130 POKE E,"*"
140 FOR K=E TO U STEP V
150 IF PEEK(K)="*" GOTO 160
155 NEXT K
169 A=(K-E)/V
170 PRINT"VON ",#$,Q," DATENSAETZEN"
180 PRINT"SIND",#4,A," ERFASST"
190 PRINT
200 PRINT"AUSWAHL DURCH KENNZIFFER"
210 PRINT; PRINT"AUFBAU.....0"
220 PRINT; PRINT"ANZEIGEN.....1"
230 PRINT; PRINT"BEGRIFF RATEN.....2"
240 PRINT; PRINT"ÄENDERN.....3"
```



```

250 PRINT; PRINT"STATUS.....4"
260 PRINT; PRINT"DATEN RETTEN.....5"
266 PRINT; PRINT"DATEN EINLESEN.....6"
269 PRINT
270 INPUT"EINGABE KENNZIFFER"W
280 IF W<0 GOTO 200
290 IF W>8 GOTO 200
300 GOTO (W*300+400)
400 REM DATEIAUFBAU
410 IF K=0 PRINT"DATEI VOLL !"; PRINT; GOTO 160
420 X=K
430 GOSUB 8000
440 K=K+V
450 POKE K,"*"
460 GOTO 160
700 REM ANZEIGEN
705 IF K=E PRINT"DATEI LEER !"; PRINT; GOTO 160
710 GOSUB 5000
720 GOSUB 5200
730 GOSUB 7000
740 IF Y=B GOTO 1890
750 X=X+V
760 Z=Z+1; Y=Y+1
770 IF Z=20 GOSUB 1850
780 IF X>=K GOTO 1890
790 GOTO 730
1000 REM BEGRIFF RATEN
1005 OUTCHAR 12
1010 GOSUB 5000
1020 FOR S=U+1 TO U+V
1030 POKE S,32
1040 NEXT S
1050 S=U+1
1055 FOR J=X TO H
1060 IF PEEK(J)#32 POKE S,45
1065 S=S+1
1070 NEXT J
1073 M=10; L=0
1075 PRINT
1080 FOR S=U+1 TO U+V
1090 OUTCHAR (PEEK(S))
1100 NEXT S
1105 PRINT
1107 IF M=0 GOTO 1250
1110 W=INCHAR; OUTCHAR W
1111 PRINT; M=0; L=L+1
1113 IF W=13 GOTO 1240
1115 S=U+1
1120 FOR J=X TO H
1130 IF PEEK(J)=W POKE S,W
1133 IF PEEK(J)#PEEK(S) GOTO 1200
1135 S=S+1
1140 NEXT J
1190 GOTO 1075
1200 M=M+1
1210 GOTO 1135
1240 L=L-1
1250 FOR J=X TO H
1260 OUTCHAR (PEEK(J))
1270 NEXT J
1275 PRINT; PRINT"NACH",#3,L," VERSUCHEN !"
1280 PRINT; GOTO 200
1300 REM AENDERN
1305 IF K=E GOTO 705
1310 GOSUB 5000
1320 GOSUB 8000
1330 GOTO 200
1600 REM STATUS
1610 PRINT"DATEI STATUS"; PRINT

```

```

1620 FOR I=E TO U STEP V
1630 WORD(I); PRINT " ";
1640 OUTCHAR (PEEK(I))
1650 OUTCHAR (PEEK(I+1))
1660 PRINT " "
1670 NEXT I
1680 PRINT; GOTO 160
1850 REM ENDE EIER SEITE
1852 TAB(20)
1855 PRINT">ENTER<";
1860 W=INCHAR; OUTCHAR W
1865 IF W#13 GOTO 1860
1870 Z=0
1880 RETURN
1890 TAB(15); PRINT"ENDE "; GOSUB 1850
1895 GOTO 200
1900 GOTO 200
2200 GOTO 200
2500 REM DATEN RETTEN
2510 FOR J=HEX(F0) TO HEX(FF)
2520 POKE J;32
2530 NEXT J
2535 PRINT"FILENAME:";
2540 X=HEX(F0); H=X+15
2550 GOSUB 3020
2560 POKE HEX(E0),E
2570 POKE HEX(E1),E/256
2580 POKE HEX(E2),K
2590 POKE HEX(E3),K/256
2600 CALL HEX(A00)
2610 CALL HEX(100)
2620 CALL HEX(A19)
2630 CALL HEX(100)
2640 GOTO 160
2800 REM DATEN EINLESEN
2810 CALL HEX(A00)
2820 CALL HEX(10F)
2830 FOR I=HEX(F0) TO HEX(FF)
2840 OUTCHAR (PEEK(I))
2850 NEXT I
2860 CALL HEX(A19)
2870 CALL HEX(10F)
2880 PRINT;GOTO 140
5000 REM ABFRAGE VON
5010 PRINT; Z=0
5020 INPUT"AB POS."W; Y=W-1
5025 IF Y<0 GOTO 5020
5030 X=E+(Y*V); H=X+V-1
5040 IF X>=K GOTO 5020
5050 RETURN
5200 REM ABFRAGE BIS
5220 INPUT"BIS POS."W; B=W-1
5230 IF B>A-1 GOTO 5220
5250 IF B<Y GOTO 5220
5360 RETURN
7000 REM AUSGABE EINES DATENSATZES
7010 PRINT
7020 FOR J=X TO X+V-1
7030 OUTCHAR (PEEK(J))
7040 NEXT J
7050 RETURN
8000 REM EINGABE EINES DATENSATZES
8010 PRINT"BEGRIF:"
8020 FOR J=X TO H
8030 IF PEEK(J)='*' GOTO 9000
8040 IF PEEK(J)='#0' GOTO 8070
8050 IF PEEK(J+1)=32 GOTO 9000
8070 OUTCHAR (PEEK(J))
8080 NEXT J

```

```

9000 W=INCHAR
9020 IF W=8 J=J-1; GOTO 9100
9030 IF W=9 J=J+1; GOTO 9120
9040 IF W=13 OUTCHAR W; RETURN
9050 POKE J,W
9060 J=J+1
9070 OUTCHAR W
9080 IF J#H GOTO 9000
9090 PRINT; RETURN
9100 IF J<X J=J+1; GOTO 9000
9110 GOTO 9070
9120 IF J>H J=J-1; GOTO 9000
9130 GOTO 9070

```

### 3. BASIC-PROGRAMM ZUM RATEN EINER DURCH DIE RND-FUNKTION ERMITTELTEN ZAHL

\*\*\*\*\*

In dem folgenden BASIC-Programm wird die Anwendung der Fensterfunktion des Monitors gezeigt. In dem Unterprogramm ab Zeile 600 werden auf ARG1(1BH) und ARG2(1DH) die Bildschirmadressen (EC00H bis F000H) mit der POKE-Anweisung gebracht (z.B.:volles Fenster). Mit der CALL-Anweisung auf Zeile 630 direkt in das Monitorprogramm (Adresse F6D1H) werden die neuen Adressen des Rollfensters übernommen. Ein anderes Rollfenster wird ab Zeile 350 eingestellt (ED40H bis F000H). Zu beachten ist, daß man vor Verlassen des Programms wieder auf volles Rollfenster stellen muß (Zeile 500).

Bei diesem Zahlenratespiel besteht die Möglichkeit, den Zahlenbereich, in welchem die Zufallszahl ermittelt werden soll, durch die Eingabe in Zeile 400 festzulegen. Mit dem Test in Zeile 405 werden ab 1 alle positiven Zahlen bis 32767 akzeptiert.

Mit der Variablen V wird die Anzahl der Versuche mitgezählt. In den Zeilen 570 und 575 wird eine Warteschleife abgearbeitet, damit die vorherige Ausschrift "AUF WIEDERSEH'N" gelesen werden kann.

```

10 REM ZAHLEN RATEN
30 GOSUB 600
70 M=5; GOSUB 700
80 PRINT"          ZAHLEN RATEN"
90 M=4; GOSUB 700
150 P=HEX(EC40); Q=HEX(EC5F)
160 R=HEX(ED1F); S=HEX(ED00)
200 FOR A=P TO Q
210 POKE A,"*"
220 NEXT A
230 FOR A=Q TO R STEP 32
240 POKE A,"*"
250 NEXT A
260 FOR A=R TO S STEP -1
270 POKE A,"*"
280 NEXT A
290 FOR A=S TO P STEP -32
300 POKE A,"*"
310 NEXT A
350 POKE HEX(1B),HEX(40); POKE HEX(1C),HEX(ED)
360 POKE HEX(1D),0; POKE HEX(1E),HEX(F0)
370 CALL HEX(F6D1)
400 INPUT"GROSSESTE ZAHL"A
405 IF A<1 GOTO 400

```

```

410 PRINT: PRINT"ICH ERMITTLE JETZT EINE"
415 PRINT: PRINT"ZAHL ZWISCHEN 0 UND",A
420 C=RND(A): V=0
430 PRINT
440 V=V+1
450 INPUT"RATE DIE ERMITTELTE ZAHL"B
460 PRINT
470 IF C<B PRINT"ZU GROSS": GOTO 430
480 IF C>B PRINT"ZU KLEIN": GOTO 430
500 PRINT"RICHTIG",B," IST DIE GESUCHTE"
510 PRINT: PRINT"ZAHL, NACH",V," VERSUCHEN!"
520 PRINT: INPUT"NEUES SPIEL ?(JA=1,NEIN=0)"D
530 IF D=1 GOTO 10
540 IF D#0 GOTO 520
545 M=10: GOSUB 700
550 PRINT"..... AUF WIEDERSE'N..."
560 M=12: GOSUB 700
570 FOR I=1 TO 5000
575 NEXT I
580 GOSUB 600
590 STOP
600 REM VOLLES FENSTER
610 POKE HEX(1B),0: POKE HEX(1C),HEX(EC)
620 POKE HEX(1D),0: POKE HEX(1E),HEX(F0)
630 CALL HEX(F6D1)
640 OUTCHAR 12
650 RETURN
700 FOR I=1 TO M
710 PRINT
720 NEXT I
730 RETURN

```

#### 4. MATHE-UEBUNGSPROGRAMM IN BASIC

\*\*\*\*\*

```

5 REM MATHE-UEBUNGSPROGRAMM
10 OUTCHAR 12
20 PRINT: PRINT".....MATHE-UEBUNG....."
25 PRINT: PRINT
30 INPUT"SCHWIERIGKEIT ? (1,2,3,4)"S
40 IF S<1 GOTO 30
45 IF S>4 GOTO 30
50 K=16000: L=180
60 IF S>3 GOTO 140
70 K=4000: L=90
80 IF S>2 GOTO 140
90 K=1000: L=45
100 IF S>1 GOTO 140
110 K=400: L=22
140 F=0: V=0
150 V=V+1
160 FOR I=1 TO 32
170 PRINT"-";
180 NEXT I
190 PRINT #4,V,". ";
200 M=RND(5)*20+200
210 GOTO M
300 A=RND(K): B=RND(K)
310 PRINT A,"+X=",A+B,: GOTO 400
320 A=RND(2*K): B=RND(2*K)
330 PRINT A,"-X=",A-B,: GOTO 400
340 A=RND(L): B=RND(L)
350 PRINT A,"*X=",A*B,: GOTO 400
360 A=RND(L): B=RND(L)
370 PRINT A*B,"/X=",A,: GOTO 400
380 B=RND(L)

```

```

390 PRINT "      X*X=",B*B,
400 INPUT " ",X
410 IF X=B GOTO 500
420 PRINT: PRINT"FALSCH !"; TAB(14)
440 PRINT"X=",#5,B
450 F=F+1: GOTO 505
500 PRINT: TAB(22): PRINT"RICHTIG ";
505 IF V<50 GOTO 150
510 W=INCHAR: OUTCHAR W
530 IF W=13 GOTO 150
600 PRINT: PRINT
610 PRINT #3,F," FEHLER IN",#4,V," AUFGABEN"
620 PRINT: PRINT: PRINT
630 Z=V-F: Y=100*Z
640 PRINT"DAS SIND",#3,Y/V," % RICHTIG !"
650 STOP

```

## 5. BASIC-PROGRAMM ZUR DARSTELLUNG VON GROESSEN IM BALKENDIAGRAMM

\*\*\*\*\*

```

5 REM BALKENDIAGRAMM
10 OUTCHAR 12
30 PRINT".....BALKENDIAGRAMM....."
35 PRINT
40 PRINT"UEBERSHRIFT:";
50 GOSUB 1000
100 PRINT"GROESSE 1. 2. 3. 4. 5."
120 GOSUB 1000
130 PRINT"EINHEIT"
140 GOSUB 1000
150 A=HEX(2B)
160 L=PEEK(A): A=A+1: H=PEEK(A)
200 FOR I=1 TO 5
210 PRINT"WERT VON",I,
220 INPUT" "C
230 @ (I)=C
240 NEXT I
250 REM MAXIMUM FINDEN
260 I=1: X=@ (I)
270 FOR I=2 TO 5
280 IF X<@ (I) GOTO 300
290 NEXT I
295 GOTO 350
300 X=@ (I): M=I: GOTO 290
350 V=X/20+1
360 F=V*20
370 POKE A,H: A=A-1: POKE A,L
380 FOR K=1 TO 11
410 PRINT #1,F
420 F=F-2*V
430 PRINT
440 NEXT K
450 B=HEX(ECE6)
470 FOR K=1 TO 10
480 POKE B,193
490 B=B+32
500 POKE B,159
510 B=B+32
520 NEXT K
540 B=HEX(IEF66)
550 FOR K=1 TO 26
560 POKE B,158
565 B=B+1
570 NEXT K
580 GOSUB 2000
590 K=1

```

```

600 PRINT #12,e(K),
610 FOR K=3 TO 5 STEP 2
620 PRINT #10,e(K),
630 NEXT K
640 K=2
650 PRINT #17,e(K)
660 K=4
670 PRINT #10,e(K)
970 INPUT W
980 IF W=1 GOTO 10
990 STOP
1000 W=INCHAR; OUTCHAR W
1010 IF W#13 GOTO 1000
1020 RETURN
2000 C=HEX(EF44)
2020 FOR K=1 TO 5
2030 C=C+5
2040 B=C
2200 Q=C(K)/V
2210 IF Q=0 GOTO 2320
2220 FOR J=1 TO Q
2240 POKE B,255
2300 B=B-32
2310 NEXT J
2320 R=C(K)-Q*V
2325 M=R*107V
2330 IF M<=3 POKE B,248; GOTO 2400
2335 IF M<=4 POKE B,249; GOTO 2400
2340 IF M<=5 POKE B,250; GOTO 2400
2345 IF M<=6 POKE B,251; GOTO 2400
2350 IF M<=7 POKE B,252; GOTO 2400
2355 IF M<=8 POKE B,253; GOTO 2400
2360 IF M<=9 POKE B,254; GOTO 2400
2400 NEXT K
3000 RETURN

```

## 6. BASIC-Programm "Turm von Hanoi"

\*\*\*\*\*

```

5 REM TURM VON HANOI
10 OUTCHAR 12
20 FOR X=1 TO 30
30 e(X)=0
40 NEXT X
50 FOR X=4 TO 30 STEP 4
60 e(X)=7
70 NEXT X
80 e(1)=1; e(5)=2; e(9)=3
90 e(13)=4; e(17)=5; e(21)=6
100 e(25)=7; e(29)=7
110 V=0
220 PRINT; PRINT; PRINT
230 PRINT" T U R M   V O N   H A N O I"
240 PRINT
250 PRINT"      1           2           3"
260 PRINT
280 FOR X=1 TO 24
290 GOTO (e(X)*10+1000)
300 NEXT X
310 IF e(3)=1 GOTO 760
320 PRINT"ANZAHL DER VERSUCHE :";V
330 INPUT"TRANSPORT VON PLATZ"A
340 INPUT"      NACH PLATZ"B
350 PRINT; PRINT
400 IF (A-1)>2 GOTO 1100
410 IF (B-19)>2 GOTO 1100

```

```

430 C=0; D=0; E=0
440 FOR X=1 TO 24 STEP 4
450 IF @ (X)>0 GOTO 480
460 NEXT X
470 GOTO 490
480 C=X
490 FOR X=2 TO 24 STEP 4
500 IF @ (X)>0 GOTO 530
510 NEXT X
520 GOTO 540
530 D=X
540 FOR X=3 TO 24 STEP 4
550 IF @ (X)>0 GOTO 580
560 NEXT X
570 GOTO 590
580 E=X
590 F=C
600 IF A=1 GOTO 640
610 F=D
620 IF A=2 GOTO 640
630 F=E
640 G=C
650 IF B=1 GOTO 690
660 G=D
670 IF B=1 GOTO 690
680 G=E
690 IF @ (G)<@ (F) GOTO 1100
700 IF G=F GOTO 1100
710 IF @ (F)>5 GOTO 1100
720 V=V+1
730 @ (G-4)=@ (F)
740 @ (F)=0
750 GOTO 1000
760 IF V>32 GOTO 800
770 PRINT"KAUM ZU GLAUBEN, SIE HABEN ES"
780 PRINT"MIT",V," VERSUCHEN GESCHAFFT !"
790 GOTO 900
800 IF V>35 GOTO 840
810 PRINT"SIE HABEN GUT GESPIELT"
820 GOTO 900
840 IF V>40 GOTO 865
850 PRINT"ETWAS MEHR UEBEN !"
860 GOTO 900
865 IF V>50 GOTO 890
870 PRINT"NERVEN BEHALTEN !"
880 GOTO 900
890 PRINT"ES IST HOFFNUNGSLOS MIT IHNEN !"
900 PRINT
910 PRINT"WOLLEN SIE WEITERSPIELEN (J/N) "
920 W=INCHAR; OUTCHAR W
930 IF W='J' GOTO 10
940 OUTCHAR 10
950 FOR B=1 TO 12
960 OUTCHAR 13
970 NEXT B
980 TAB(5); PRINT"AUF WIEDERSEH'N"
985 PRINT; PRINT; PRINT
990 STOP
1000 PRINT" ";
1005 GOTO 300
1010 PRINT" * ";
1015 GOTO 300
1020 PRINT" *** ";
1025 GOTO 300
1030 PRINT" ***** ";
1035 GOTO 300
1040 PRINT" ***** ";
1045 GOTO 300
1050 PRINT"***** " ;

```

```

1055 GOTO 300
1060 PRINT " "
1065 GOTO 300
1070 PRINT
1075 GOTO 300
1080 OUTCHR 12
1090 GOTO 220
1100 PRINT; PRINT
1110 PRINT " F E H L E R "
1120 FOR Y=1 TO 500
1130 NEXT Y
1140 GOTO 320

```

## 7. BASIC-PROGRAMM "MASTERMIND"

\*\*\*\*\*

```

5 REM MASTERMIND
10 OUTCHAR 12
20 PRINT; PRINT "MASTERMIND"
30 PRINT; PRINT; PRINT
40 PRINT " ICH HABE EINE 4-STELLIGE "
50 PRINT " PRINT "ZUFALLSZAHLE ERMITTELT."
60 PRINT; PRINT "RATEN SIE DIESE ZAHLE !"
70 PRINT; PRINT "RICHTIGE ZAHLE AN RICHTIGER "
80 PRINT; PRINT "STELLE: *"
90 PRINT; PRINT "RICHTIGE ZAHLE AN FALSCHER "
100 PRINT; PRINT "STELLE: *"
110 PRINT; PRINT "KANN ICH BEGINNEN ? (ENT): ",
120 W=INCHAR; OUTCHAR W
200 A=RND(9); M=A; B=RND(9); N=B
220 C=RND(9); O=C; D=RND(9); P=D; V=0
250 A=M; B=N; C=O; D=P
260 V=V+1; PRINT; PRINT #2, V, ". ";
270 INPUT "EINGABE " F
280 TAB(20)
290 G=F/1000
300 H=(F-(G*1000))/100
310 I=(F-(G*1000)-(H*100))/10
320 J=F-(G*1000)-(H*100)-(I*10)
400 S=0
410 IF A#G GOTO 450
420 S=S+1
430 PRINT "* ";
440 A=10; G=11
450 IF B#H GOTO 500
460 S=S+1
470 PRINT "* ";
480 B=10; H=11
500 IF C#I GOTO 550
510 S=S+1
520 PRINT "* ";
530 C=10; I=11
550 IF D#J GOTO 600
560 S=S+1
570 PRINT "* ";
580 D=10; J=11
590 IF S=4 GOTO 1000
600 IF G#B GOTO 630
610 PRINT "* ";
620 B=10; GOTO 690
630 IF G#C GOTO 660
640 PRINT "* ";
650 C=10; GOTO 690
660 IF G#D GOTO 690
670 PRINT "* ";
680 D=10

```



```

690 IF H#A GOTO 720
700 PRINT"# ";
710 A=10; GOTO 780
720 IF H#C GOTO 750
730 PRINT"# ";
740 C=10; GOTO 780
750 IF H#D GOTO 780
760 PRINT"# ";
770 D=10
780 IF I#A GOTO 810
790 PRINT"# ";
800 A=10; GOTO 870
810 IF I#B GOTO 840
820 PRINT"# ";
830 B=10; GOTO 870
840 IF I#D GOTO 870
850 PRINT"# ";
860 D=10
870 IF J#A GOTO 900
880 PRINT"# ";
890 A=10; GOTO 1000
900 IF J#B GOTO 930
910 PRINT"# ";
920 B=10; GOTO 1000
930 IF J#C GOTO 1000
940 PRINT"# ";
1000 PRINT
1010 IF S=4 GOTO 1200
1020 IF V<30 GOTO 250
1030 PRINT
1040 PRINT"ES IST ZWECKLOS MIT IHNEN !"
1050 PRINT; PRINT"DAS ERGEBNIS WAR:";
1060 PRINT#2,M,#2,N,#2,O,#2,P
1070 PRINT
1080 INPUT"NOHMAL ? (JA=1,NEIN=09:"Z
1090 IF Z=1 GOTO 10
1100 OUTCHAR 12
1110 FOR I=1 TO 10
1120 OUTCHAR 13
1130 NEXT I
1140 TAB(5)
1150 PRINT"AUF WIEDERSEH'N"
1160 PRINT; PRINT; PRINT
1170 STOP
1200 PRINT; PRINT"RICHTIG !"; PRINT
1210 IF V=8 GOTO 1280
1220 PRINT"EIN BLINDES HUHN FINDET AUCH"
1225 PRINT; PRINT"MAL EIN KORN"
1230 GOTO 1070
1240 IF V>8 GOTO 1280
1255 PRINT; PRINT"NACHGEDACHT"
1260 GOTO 1070
1280 IF V>14 GOTO 1310
1290 PRINT"MEHR UEBEN !!!!!"
1300 GOTO 1070
1310 PRINT"GERADE NOCH GESCHAFFT"
1320 GOTO 1070

```

## 8. BASIC-PROGRAMM "23 STREICHHOELZER"

\*\*\*\*\*

```

5 REM 23 STREICHHOELZER
10 OUTCHAR 12
20 FOR I=1 TO 10
30 PRINT
35 NEXT I

```

```

40 PRINT "DAS SPIEL DER"
60 PRINT; PRINT "23 STREICHHOELZER!"
70 FOR I=1 TO 5000
80 NEXT I
85 OUTCHAR 12
90 FOR I=1 TO 10
100 PRINT
110 NEXT I
120 PRINT "HIER SIND 23 STREICHHOELZER!"
140 PRINT; PRINT "SIE NEHMEN STETS 1, 2 ODER 3."
160 PRINT; PRINT "DARAUF NEHME ICH 1, 2 ODER 3."
180 PRINT; PRINT "WER DAS LETZTE STREICHHOLZ"
200 PRINT; PRINT "NIMMT, HAT VERLOREN:"
210 PRINT; PRINT
220 PRINT; PRINT "VERSTANDEN? ES GEHT LOS !!!"
230 FOR I=1 TO 10000
240 NEXT I
250 OUTCHAR 12
300 PRINT; PRINT; PRINT; PRINT
310 M=23
320 Z=0
325 IF M=1 GOTO 1000
330 PRINT "HIER SIND JETZT",#3,M," HOELZER."
400 Q=HEX(EE24)
410 FOR K=1 TO 5
420 Z=Z+1
440 IF Z<=M POKE Q,161
450 Q=Q+1
460 NEXT K
470 Q=Q+1
480 IF Z<M GOTO 410
500 PRINT
510 INPUT "WIEVIELE NEHMEN SIE"N
515 PRINT
530 IF N>3 GOTO 900
540 IF N<1 GOTO 900
550 IF N>M GOTO 900
560 M=M-N
580 IF M=1 GOTO 800
590 R=M-4*(M/4)
600 IF R#1 GOTO 650
610 C=RND(3)
620 GOTO 680
650 C=3+R-4*((R+3)/4)
660 M=M-C
665 IF M=0 GOTO 800
670 OUTCHAR 12
680 PRINT "ICH NEHME",#3,C
690 PRINT; GOTO 320
800 OUTCHAR 12
810 FOR I=1 TO 15
820 PRINT
830 NEXT I
840 PRINT "HERZLICHEN GLUECKWUNSCH,"
845 PRINT; PRINT "SIE HABEN GEWONNEN !!!!"
850 PRINT; INPUT "NOCH EINMAL ? JA=1"A
880 IF A=1 GOTO 250
890 STOP
900 PRINT "NA...NICHT MOGELN !!!!"
910 GOTO 510
1000 FOR I=1 TO 20
1010 PRINT
1020 NEXT I
1030 PRINT "TJA...DAS LETZTE HOLZ WERDEN"
1040 PRINT; PRINT "SIE WOHL NEHMEN MUESSEN !!!!"
1045 A=HEX(EE23)
1050 Q=A
1055 POKE Q,207
1060 Q=Q+1

```

```
1065 FOR I=1 TO 5
1070 IF Q<HEX(EE2E) POKE Q,160
1075 Q=Q+1
1080 NEXT I
1090 Z=0
1095 Q=A-32
1100 FOR I=1 TO 5
1110 POKE Q,127+RND(8)
1150 Q=Q-32
1160 NEXT I
1170 Z=Z+1
1180 IF Z<4 GOTO 1095
1200 Q=A
1210 FOR I=1 TO 6
1220 POKE Q,32
1230 Q=Q-32
1240 NEXT I
1250 A=A+1
1260 IF A<HEX(EE2E) GOTO 1050
1300 GOTO 850
```